



TOWN OF MEDWAY

WATER/SEWER DIVISION

RULES & REGULATIONS

CHARLES RIVER POLLUTION CONTROL DISTRICT

WASTEWATER TREATMENT FACILITY REGULATIONS

REVISED 05/13/15

REVISED 01/07/16

REVISED 04/13/17

REVISED 12/17/19

REVISED 12/20/2021

TOWN OF MEDWAY  
DPW WATER/SEWER DIVISION  
RULES & REGULATIONS  
CHARLES RIVER POLLUTION CONTROL DISTRICT  
WASTEWATER TREATMENT FACILITY REGULATIONS

ARTICLE I - DEFINITIONS ..... 1  
ARTICLE II - APPLICATION FOR SERVICE ..... 4  
ARTICLE III - LICENSING DRAIN LAYERS ..... 5  
ARTICLE IV - WATER, GENERAL ..... 6  
ARTICLE V - WATER MAINS CONSTRUCTION METHODS AND MATERIALS ..... 9  
ARTICLE VI - WATER SERVICES AND METERING ..... 12  
ARTICLE VII - WATER USE RESTRICTIONS ..... 14  
ARTICLE VIII – SEWER, GENERAL ..... 14  
ARTICLE IX – SEWER, CONSTRUCTION METHODS ..... 17  
ARTICLE X - PAYMENT FOR SERVICE ..... 18  
ARTICLE XI - FEES ..... 19

APPENDIX A - SPECIFICATIONS FOR LAYING PUBLIC SEWERS, BUILDING SEWERS, AND  
MANHOLES .....

Board of Water/Sewer Commissioners/Selectboard

\_\_\_\_\_  
MaryJane White, Chair

\_\_\_\_\_  
Dennis Crowley, Vice-Chair

\_\_\_\_\_  
Frank Rossi

\_\_\_\_\_  
John Foresto

\_\_\_\_\_  
Glenn Trindade

Date:            Amended: December 2021

The following regulations are a part of the contract with every person who takes municipal water and/or discharges into the municipal sewer system and govern the relations between the DPW Water/Sewer Division and its customers. Every person taking water or discharging to the municipal sewer system shall be considered to express consent to be bound thereby.

## **ARTICLE I - DEFINITIONS**

- A1.1      **APPLICANT** - Any person requesting approval to connect to the Town of Medway water supply or to discharge wastewaters into municipal facilities.
- A1.2      For matters concerning the municipal water supply and the Town of Medway sanitary sewerage system or his authorized deputy.
- A1.3      **BOD - (BIOCHEMICAL OXYGEN DEMAND)** -The quantity of dissolved oxygen, expressed in milligrams per liter by weight used in the biochemical oxidation of wastewater in five (5) days at 20 deg. C. (68 deg. F) under standard laboratory procedures.
- A1.4      **BUILDING DRAIN** - The part of the lowest horizontal piping or conduit to a drainage system which receives the discharge from: soil, waste, and other drainage pipes inside the walls of the building and conveys it to the building sewer, beginning ten (10) feet (3.1 meters) outside the inner face of the building wall.
- A1.5      **BUILDING SEWER** - The extension from the building drain to the public sewer or other place of disposal.
- A1.6      **CHLORINE DEMAND** - The amount of milligrams per liter of chlorine required to be added to water, wastewater, or other liquid to achieve a combined chlorine residual after fifteen (15) minutes contact of one (1.0) milligram per liter.
- A1.7      **COMMISSIONERS** -The members of the Town of Medway Water/Sewer Commission.
- A1.8      **CUSTOMER** - The individual owner, the corporation or association managing the property being serviced by the Department. The owner of the property is ultimately responsible for any outstanding water and sewer charges.
- A1.9      **COMBINED SEWER** - Shall mean sewer receiving both wastewater and surface runoff from storm events.
- A1.10     **CRPCD** -The Charles River Pollution Control District.
- A1.11     **DEPARTMENT** - The Department of Public Works (DPW). Water and Sewer Division of the Town of Medway.
- A1.12     **DISCHARGE** - Flow from a conduit, sewer, drain, outfall, pump, pipe, tank or treatment process, or any emission, intentional or unintentional including but not limited to flow resulting from spilling, leaking, seeping, pumping, pouring, emitting, emptying, depositing, dumping, releasing, injecting, escaping, leaching or infiltrating whether direct or indirect.

- A1.13 DOMESTIC WASTEWATER - The liquid wastes discharged from sanitary convenience such as toilets washrooms, sinks, showers, drinking fountains, small laundries and from kitchens, cafeterias, and free of industrial wastes or toxic materials.
- A1.14 EXCESSIVE – The amounts or concentrations of a constituent of a wastewater which in the judgment of the municipality:
- a. will cause damage to any facility;
  - a. will be harmful to a wastewater treatment process;
  - b. cannot be removed in the treatment works to the degree required in the limiting stream classification standards of the Charles River Pollution Control District;
  - c. can otherwise endanger life or property, or;
  - d. Can constitute a nuisance.
- A1.15 EASEMENT - An acquired legal right for the specific use of land owned and maintained by others, whether recorded or by prescription.
- A1.16 FACILITIES - Includes structures, conduits, pumping stations, treatment and disposal works, and other appurtenances for the purpose of treating, storing and distributing of drinking water and collecting, treating and disposal of domestic and/or industrial wastewater and stormwater.
- A1.17 GARBAGE - The water resulting from the handling preparation, cooking and serving of food. It is composed largely of putrescible organic matter and its natural moisture content.
- A1.18 INDUSTRIAL WASTEWATER - The liquid wastes from industrial manufacturing processes, laboratories, trades or businesses which predominate as distinct from domestic wastewaters.
- A1.19 INDUSTRY - An establishment with facilities for mechanical, testing, trade or manufacturing purposes.
- A1.20 LICENSED DRAINLAYER - A contractor approved by the Department to install approved water, drain and/or sewer mains and approved water, drain and/or sewer service piping, fixtures or appurtenances connecting to Town systems.
- A1.21 MAIN - The supply pipe laid in the street or easement to which water connections are made; or the discharge pipe laid in the street or easement to which individual sewer connections are made.
- A1.22 MAY - Is used as a permissive term, but with prior approval.
- A1.23 MUNICIPALITY - The Town of Medway Department of Public Works Division of Water & Sewer.
- A1.24 NATURAL OUTLET - Any outlet into a watercourse, pond, ditch, lake or other water body at surface or groundwater.
- A1.25 PERSON - The individual owner, the corporation or association managing a property being serviced by the Department. The owner of the property is ultimately responsible for any outstanding water or sewer charges.

- A1.26 PRIVATE SERVICE - The water service pipe, fittings and fixtures from the curb stop to the meter in the building. The sewer pipe from the building to the street up to and including the connection to the sewer main line.
- A1.27 PREMISES Refers to:
- a. A building under one roof owned by a customer and occupied as a residence or place of business;
  - b. A combination of buildings owned by a customer, in one common enclosure, or occupied by one family, or one corporation or firm as a residence or place of business;
  - c. A building owned by a customer having a number of apartments, office or lofts which are rented to tenants, and using in common one hall and one or more means of entrance, or;
  - d. A condominium association serving one or a combination of buildings in one common enclosure.
- A1.28 PROPERLY SHREDDED GARBAGE - The garbage that has been shredded to such a degree that all particles will be carried freely under the flow conditions normally prevailing in public sewers, with no particle greater than one-half (1/2) inch (1.27 centimeters) in any dimension.
- A1.29 PH – The negative logarithm to the base ten of the hydrogen ion activity in gram moles per liter of solution.
- A1.30 PUBLIC SEWER - A sewer in which all owners of abutting properties have equal rights to and is controlled by the municipal authority.
- A1.31 RECEIVING WATERS - Any watercourse, river, pond, ditch, lake, aquifer, or body of surface or groundwater receiving discharge of wastewaters.
- A1.32 SANITARY SEWER - A sewer which carries domestic and/or industrial wastewaters and to which surface runoff from storms and groundwater is not intentionally admitted.
- A1.33 SEPTAGE - The waste from a septic tank or cesspool or portable sanitary facilities.
- A1.34 SERVICE - A pipe or conduit for carrying water from the water main to the building or wastewater from a building to a sewer main.
- A1.35 SEWER - A pipe or conduit carrying wastewater.
- A1.36 TOWN SERVICE - The water pipe that is running from the water main to the curb stop.
- A1.37 SHALL - Is a mandatory term, referring to standards and practices.
- A1.38 STORM DRAIN - A pipe or conduit for conveying rainwater, groundwater, subsurface water, condensate, cooling water or other similar discharge to a storm drain or combined sewer but excludes wastewater and industrial wastes, other than unpolluted cooling water.
- A1.39 SUSPENDED SOLIDS (SS) - Solids that either float on the surface of or are in suspension in water, wastewater, or other liquids, and which are removable by laboratory filtering and are referred to as non-filterable residue in the laboratory test prescribed in “Standard Methods for the Examination of Water and Wastewater”.

- A1.40 TOWN - As used in these regulations shall mean the Town of Medway Department of Public Works, Division of Water and Sewer and the Board of Water and Sewer Commissioners.
- A1.41 WASTES - Substances in liquid, solid or gaseous form that can be carried by water.
- A1.42 WASTEWATER - The spent liquid and water-carried wastes from residences, municipal & commercial buildings, industrial plants and institutions together with such ground, surface and storm waters as may be present.
- A1.43 WASTEWATER TREATMENT PLANT - Any arrangement of devices and structures used for treating wastewater.
- A1.44 WASTEWATER WORKS - All structures, equipment and processes for collecting, pumping, treating and disposing of wastewater.
- A1.45 WATERCOURSE - A channel in which the flow of water occurs, either continuously or intermittently.

## **ARTICLE II - APPLICATION FOR SERVICE**

- A2.1 All applications for water and/or sewer service must be made in writing by completing the proper form including proposed layout drawing provided by the Department. The application for service must be made by or on behalf of the property owner. The application shall state fully the purpose for which the service is intended to be used, and shall be delivered to the Department of Public Works office. At least three business days is required to process an application.
- A2.2 No agreement will be entered into by the Department with any applicant until all arrears and charges due by the applicant at any premises now or heretofore occupied or owned by the applicant shall have been paid.
- A2.3 When accepted by the Department, the application shall constitute a contract between the Department and the applicant obligating both parties to comply with these Rules and Regulations of the Town of Medway.
- A2.4 Applications for a water and/or sewer service installation will be accepted subject to there being an existing main with sufficient capacity and/or pressure as determined by the Department in a street or right-of-way abutting the premises to be served. The contract in no way obligates the Department to extend its mains to service the premises under construction. Sewer applications shall be submitted to the Charles River Pollution Control District for their consideration and approval.
- A2.5 When a prospective customer has made application for a new service, or has applied for the reinstatement of an existing service, damage caused by any deficiency in the plumbing which the service will supply shall be the risk of the customer.
- A2.6 Subdivision review shall be performed by the Department in collaboration with and under the purview of the Planning and Economic Development Board.

- A2.7 All applicable fees as identified in the Fee Schedule for repairs and installation of new water and/or sewer service connections to residential, commercial or industrial premises shall be charged by the Department at the time of application.
- A2.8 Street Opening Permits shall be obtained from the Department of Public Works office prior to excavation in any public way.
- A2.9 Trench Permits, if excavation meets Massachusetts Department of Professional Licenses requirements for such, shall be obtained from the Department of Professional Licenses office prior to any excavation in any public way. The Building Department shall be notified, and permits obtained for trenching on private property.
- A2.10 An inspection of all water and/or sewer service installations or renewals is required with at least two business days' notice. Applicant shall contact the Department of Public Works 48 hours prior to work to schedule required inspections.
- A2.11 All Sewer Permits must meet all rules and regulations set by CRCPD, [www.charlesriverpcd.org](http://www.charlesriverpcd.org).

**Demolitions.** Before a building or structure is demolished, the owner shall notify the Department by submitting a permit application for the removal or cutting and capping of all water, sewer and fire pipes. Prior to demolition, the Department shall gain access to the property for the removal of Town-issued meters, fixtures and appurtenances. The Department at its sole discretion may require the owner to submit a site plan. The Department shall inspect the work to ensure that the services are removed or properly cut and capped in accordance with Department specifications prior to backfilling.

- A2.12 All domestic water services must be disconnected at the Main in accordance with Department specifications.
- A2.13 All sanitary sewer and storm sewer connections must be plugged and capped at the main wye connection in accordance with Department specifications.

### ARTICLE III - LICENSING DRAIN LAYERS

- A3.1 All work related to the installation of water and/or sewer in the Town shall only be performed by persons licensed by the Department. The licensed contractor or licensed designee must perform the work and be at each site during construction. All licensees are required to give personal attention to all installations and shall, employ only competent workers.
- A3.2 Plumbers and drain layers of established reputation and experience will be licensed by the Department as Drain Layers authorized to perform work, subject to compliance with the following requirements:
  - a. Applicants for licenses are required to pay a filing fee as Drain Layer, payable to the Town of Medway.
  - b. Insurance requirements to be submitted with application are as follows:

- b.1 Public Liability Insurance Certificate with XCU \$100,000 - \$300,000
- b.2 Auto Insurance per State Statute
- b.3 Workmen's Compensation per State Statute
- b.4 Performance Bond \$5,000
- b.5 Said Insurance shall indemnify the Town against any and all claims, liability or actions for damages, incurred in or in any way connected with, the performance of work by a Drain Layer in the performance of his work. All insurances shall remain in full force and effect for the full term of the license issued by Department.

c. Applications for licenses will be approved or disapproved within fourteen (14) days after filing the application.

- A3.3 All licenses expire on December 31st of each year and no licenses are transferable. The fee for renewal thereof shall be due and payable on or before January 1st of each year as well as the insurances stated in section 2. No permits will be issued to a contractor who has not renewed their license.
- A3.4 Contractors shall comply with O.S.H.A. and Department of Labor Standards regulations. Work site shall be maintained at all times in accordance with said Regulations.
- A3.5 Work shall be performed during the Department's standard work week and working hours. No holiday or weekend construction shall be allowed except by permission of the Department.
- A3.6 Water and/or sewer permits shall be obtained before commencing work or installation will not be inspected nor approved and Drain Layers License may be suspended. Unpermitted work shall either be removed or made visible for inspection. Department shall reserve right to levy fines or take further punitive actions. Department may not issue future permits until any and all unresolved issues are resolved to the Department's satisfaction
- A3.7 As-Builts for service connections shall be completed on forms provided by the Department and ready when an inspection is requested. Failure to provide as-builts will require re-inspection with fees and is cause for suspension of Drain Layer's License. No new permits will be issued unless as-builts on prior installations were submitted to the Department at the time of inspection.
- A3.8 No person, firm or corporation except a duly licensed Drain Layer shall work on pipes, fittings or fixtures connected to Town systems located outside of a building foundation.
- A3.9 DPW reserves the right to revoke any license if any provision of said license is violated.
- A3.10 Any variation from these Rules and Regulations shall receive prior approval by DPW before implementation.

**ARTICLE IV - WATER, GENERAL**

- A4.1 Subject to prior approval by the Department, water service may be discontinued or a fine may be imposed upon reasonable notice for any one of the following reasons:
  - a. willful waste of water;

- b. tampering with meter or meter seal;
- c. property vacant, furnishings removed, and whereabouts of owner unknown;
- d. cross-connecting potential or actual Department service with any hazard other supply source; or
- e. refusal of reasonable access to premises or to meter.
- f. nonpayment of service.

When water has been turned off for any of the above reasons, or upon written order of the customer, a fee will be charged to restore service.

- A4.2 The Department will not permit its mains or Town service pipes to be connected with any other source of supply not approved by the Department nor will the Department permit its mains or service pipes to be connected in any way to any pipes, tanks, vats, or other pollution which can flow back into the Department mains. Shall conform to State Regulations covered under 310 C.M. R. 22.22, M.G. L. Chap.111, Sect. 160A or as amended.
- A4.3 Any authorized agent of the Department shall have the right of access at all reasonable hours to the premises supplied with water for the purpose of reading meters, examining fixtures and pipes, observing the manner of using water or for any other purpose which is necessary in the conduct of Department business. No person shall be deemed to be an authorized agent of the Department entitled to such access unless the person displays proper identification.
- A4.4 The Department shall have the right to interrupt the water supply to make repairs, changes or connections to its mains or other equipment. Reasonable efforts will be made to notify the customer in advance of any discontinuance of service, but, in time of emergency, the Department may not be able to do so. The Department shall not be responsible for any loss or damage incurred by said shut off, or while making repairs.
- A4.5 The Department shall not be liable for any damage or inconvenience suffered by the customer as a result of any cause beyond Departmental control. The Department shall have the right to reserve a sufficient supply of water at all times in its storage facilities to provide for fires or any other emergencies, and may restrict or regulate the use of water by customers in case of scarcity, or whenever required to protect the public welfare.
- A4.6 Water from hydrants or other fire protection systems shall be used only for fire protection purposes. Testing of hydrants and fire-fighting apparatus shall be granted only with prior written permit approval from the Department. Drawing water from a Fire Service for Domestic use shall be considered theft and will be cause for penalties accordingly.
- A4.7 No person will be permitted to insert or cause to be inserted any faucet or piping into any water pipe, or connect any service pipe for conveying water from any of the mains or distributor pipes to any house, building or manufacturing, or for any other purpose without written permission of DPW.
- A4.8 Request for private use of a public fire hydrant must be approved by the Department in advance. Applicable fees will be assessed to pay for all required equipment including meters and backflow devices as well as water usage.

- A4.9 No water user shall supply water to parties not entitled to use of the water or resell water without written permission of the Department.
- A4.10 Any water used for cooling condensate purposes must be recycled to the extent practicable and not allowed to run to waste. Safeguards shall be taken to eliminate all unprotected cross connections.
- A4.11 The Commissioners shall set a charge and fee structure for all work performed by the Water and Sewer Division.
- A4.12 All apparatus deemed appropriate and places supplied with water must be accessible at all times for inspection by the Department and all pipes and fixtures shall be subject to rejection by the Department if considered unsuitable for the purpose.
- A4.13 The Department shall not be responsible for damages caused by discolored or dirty water resulting from the use of any hydrant, the breaking of any pipe or any other disturbance of the water system (e.g., "water breaks").
- A4.14 The Commissioners reserve the right to establish such further rules and regulations from time to time as it deems necessary.
- A4.15 Winter Hazards
- a. In the event of an interrupted water supply due to a frozen pipe, the Department will determine the location and cause of the stoppage. If the stoppage is in the private service and is due to improper installation or breakage after the Department curb stop, the repairs shall be the responsibility of the customer.
  - b. All customers using water must furnish all internal piping, connection fixtures, and keep them in good repair and protected from frost at their own expense. The Town will not be liable for any damage resulting from failure by the customer to adhere to the above conditions.
  - c. The water shall not be left running to prevent freezing or for other purposes, without the permission of the Department.
  - d. Meters and associated hardware damaged due to owner negligence and/or freezing within unheated premise areas will be replaced with the cost of replacement and service call borne by owner.
- A4.16 No allowance for loss of water due to leakage, failure of private piping or fixtures or consequent damage shall be sought from Water and Sewer Commission.
- A4.17 Once a leak has been verified on a private service, the owner shall have fourteen (14) days to make repairs or shall face punitive actions including but not limited to fines and service termination.
- A4.18 Any emergency call responded to and found not to be Department related shall be charged at a rate established in the fee schedule.
- A4.19 The owner of any premises having a private well or other source will not be allowed to run said system within the same structure as the public water supply system or to have a physical

connection between the private well system and the public water supply system. Owner shall comply with rules and regulations in accordance with CMR 22.22.

#### **ARTICLE V - WATER MAINS CONSTRUCTION METHODS AND MATERIALS**

- A5.1 A plan shall be required showing location of proposed main, all gate valves and hydrants, profile of road and lot lines. At completion of work, owner shall provide the Department with "As-Built Drawings" showing ties to and location of valves, service connections and boxes. Financial deposits will be held by the Department until all obligations are fulfilled. Any work not completed per permit specifications may be performed by the Department using said financial deposits.
- A5.2 Contractors or developers shall design a water system for possible future developments and construct water mains to interconnect with existing or future water system at their own expense.
- A5.3 Only licensed Drain Layers shall make any connections or perform work on any part of the water distribution system. The Department shall be notified forty- eight (48) hours (Two Business Days) prior to any and all work performed, including that on private property.
- A5.4 The Department shall approve all materials used in making a service connection and shall inspect all work upon completion and prior to backfill of trench. All pipes fittings, and appurtenances shall meet AWWA and Department Standards.
- A5.5 There shall be three (3) valves at all roadway intersections greater than one-thousand (1,000) feet from the closet intersecting main.
- A5.6 All hydrants shall be standardized type and specifications of the Water Division. Hydrants shall be located at property lines when possible and shall not be spaced more than five hundred (500) feet apart. There shall also be a gate valve for every hydrant. All hydrants shall be backed with 0.25 cubic yards of concrete or approved thrust block against trench wall. Hydrants shall also be surrounded with 1 cubic yard of 3/4-inch stone for drainage. See Construction Detail.
- A5.7 Hydrants on private property shall be owned and maintained by the owner at their expense. If owner fails to maintain or repair inoperable hydrants after notification, the Department reserves the right for the purposes of public safety, to inspect and repair any hydrant at the owner's expense of material and labor. The Department does not, by this regulation, take responsibility for the condition of private hydrants or any possible court action which may result from fire or accident.
- A5.8 All persons or firms having private fire connection for sprinklers or fire hydrants on the premises or in buildings are forbidden to use the water for any purpose except fires and shall accept ownership of appurtenances and related necessary maintenance and repairs.
- A5.9 All mains shall be at least eight (8) inches in diameter at a depth of five (5) feet and shall be cement lined ductile iron Thickness Class 52.
- A5.10 Minimum size water main may be reduced from eight (8) inch to six (6) inch if the main is no more than two hundred fifty (250) linear feet, if there is no more than three (3) one (1) inch service connections, if the parcel of land is landlocked with no possibility of extensions of road or main and if no additional lots or services can be made through the Planning Board

or Zoning Board or of servicing abutting lot(s) not serviced by Town water, the main may be reduced to six (6) inch with termination at a hydrant.

- A5.11 All pipe work shall remain open for inspection by the Department. The work shall be backfilled by hand for the first foot using clean sand and have locating tape in cases where non-metallic pipe is used. Tracer wire shall be installed, connected and accessible from the top nut of the curbstop shutoff through to the meter inside the foundation.
- A5.12 Trenches shall be compacted by the approved method designated by the Department and may be tested with cost of said test paid by owner.
- A5.13 All job sites are to be left in a neat and orderly fashion and work will be performed in a professional manner. All sites shall be returned to their original condition at the conclusion of the project. Preconstruction photographs or video may be required at the owners expense.
- A5.14 All mains or services shall be installed no closer than three (3) feet vertically or ten 10 feet horizontally from sewer line or encased in concrete or sleeve segments not meeting these criteria.
- A5.15 All mains shall be pressure and leak tested as per American Water Works Association (AWWA) specifications at 50 PSI over static pressure or 150 PSI, whichever is greater, for a period of two (2) hours.
- A5.16 All mains shall be disinfected as per one of the methods described by AWWA C651 after passing the pressure and leak testing. After successfully passing disinfection, all mains shall be flushed of all sediment and chlorine and have residual chlorine of no higher than 3 PPM before it is accepted for use. Two (2) consecutive "passing" coliform test samples shall be taken and sent to a MADEP Certified Lab and the test results shall be sent to the Department.
- A5.17 The contractor or developer shall, make all necessary arrangements with the proper departments at their own expense, for the safety of all traffic, health protection, and safe travel of the general public on all traveled ways by barriers, police supervision, and/or other means as directed by said departments.
- A5.18 The contractor or developer shall maintain safe conditions of all roadways and passageways over excavations and shall promptly fill in depressions caused by the settling of work.
- A5.19 The contractor or developer shall guarantee all work performed and material installed to be free from defects, and shall keep same in repair or replace any defective material for a period of one (1) year at no cost to the Town.
- A5.20 Only approved lubricants shall be used on pipe installations. No petroleum products, grease, or fats shall be permitted.
- A5.21 Services shall be copper from the main to curbstop. AWWA approved materials shall be allowed downstream of the curbstop. PVC or PE Pipe shall not be installed in the winter months when the temperature is below 30 degrees. No frozen material shall be used for backfill.
- A5.22 Pipe shall be laid in dry trenches; groundwater shall be pumped out and a stone bed put in place if the trench is not stable.

- A5.23 All fittings shall be restrained using mechanical or push-on joint restraints or threaded rods for pipe connections using couplings or as approved by the Department.
- A5.24 The road box and service box shall be centered over the gate, set at grade, and accessible at all times. No risers shall be allowed without the prior written approval from the Water and Sewer Division.
- A5.25 During construction the end of the water pipe shall be protected during installation to prevent groundwater, dirt, or animals from entering pipe.
- A5.26 DIG SAFE shall be called before beginning work. The Department shall also be notified of the DIG SAFE number and start date and time.
- A5.27 Damage to private and public infrastructure services or mains shall be repaired by the contractor under the supervision of the Department. If unable, the Department will repair at an hourly rate for equipment, materials and personnel. Applicable service fees will be assessed in cases of negligence.
- A5.28 Saddles shall be used in making taps on PVC pipe or Cement Lined Ductile Iron Class 50 or less.
- A5.29 Water and/or sewer mains and appurtenances in subdivisions shall be completed in their entirety. Partial work shall only be permitted with written approval from the Town and with a bond posted for utility remaining to be completed.
- A5.30 Disinfection of repaired and new installation shall be in accordance with MADEP and AWWA standards.
- A5.31 All pipes shall be Cement Lined Ductile Iron 150 PSI Class 52 tar coated bell and spigot with push-on joints. C-900 PVC shall be allowed to connect to existing C-900 PVC only.
- A5.32 Fittings shall be AWWA Standard Cement Lined Cast or Ductile Iron , tar coated 150 PSI .
- A5.33 Valves - Resilient Seal, open left. Resilient gate valves shall meet the most recent version of the AWWA standard specification AWWA C509 & C550. Butterfly valves shall meet the most recent version of AWWA standard specification C504.
- A5.34 Hydrants - American, Darling model B-84B, open left. Factory painted in Town of Medway standard color with National Fire Protection Association (NFPA) standard threads and two 2-1/2 inch nozzles and one 4-1/2 inch nozzle.
- A5.35 Valve boxes shall be manufactured in the United States and be cast iron, tar coated, sliding, heavy pattern type, consisting of three (3) pieces; a flanged bottom piece, a flanged top piece, and a cover with two (2) lifting holes and the word "water" cast on the top. A minimum 6 inch overlap is required between sliding sections. The inside diameter of boxes shall be at least 5 1/4 inches and lengths shall be as necessary to suit ground elevation.
- A8.1 Water shut-off box and curb stop box shall be Erie style.
- A5.36 Corporation Stops shall be all brass, lead free, compression fitting without drains.

Service Pipe

- (A) Type K Copper
- (B) Type 3406 160 PSI PE  
Class 52 Cement-lined Ductile Iron

- A5.37 Meters – Sensus meters with Automatic meter, readings in cubic feet. Fire services shall be equipped with detector check ports near the backflow preventor.
- A8.2 All materials used in the drinking water system shall comply with 40 CFR 143.10 - 143.20 “Use of Lead Free Pipes, Fittings, Fixtures, Solder, and Flux for Drinking Water”

**ARTICLE VI - WATER SERVICES AND METERING**

- A6.1 Original service pipe and connections from the main to the curb stop at the property line will be installed by the Department, or under its direction, at the expense of the customer at the prevailing rate for said installation. All service pipes shall have a minimum cover of five (5) feet. To the extent not prescribed by State and Municipal Regulations, materials and methods of construction shall be approved by the Division. If the service has not been installed in accordance with the Department’s reasonable requirements, water will not be turned on until all defects have been remedied.
- A6.2 The Town service pipe from main to curb stop in the traveled way shall be maintained or replaced as necessary by the Department at the Department’s expense. The private service pipe from the curb stop to the customer premises will be maintained by the customer at the expense of the customer and in a manner satisfactory to the Department.
- A6.3 Curb stops will not be used by the customer or his agent for turning on or shutting off the water supply. The customer control of water supply shall be by means of a separate valve, located usually just inside the building wall. Curb stops are for the exclusive use of the Department.
- A6.4 On future installations or reinstallations of service lines, only one premises will be supplied by one service pipe, unless otherwise determined by the Department.
- A6.5 The owner shall be responsible for street excavation and all their costs of installation of the water service from curb stop to meter. The meter shall be purchased by the owner and installed by and maintained by the Department or a designer.
- A6.6 All water services shall be installed no closer than 10 feet from a septic or sewer line. If a water service line must be within 10 feet of a sewer or septic line, the sewer or septic line must be encased in concrete or sleeved in ductile iron pipe.
- A6.7 Valves shall be required before and after all meters, and back flow devices shall be installed if, in the opinion of the Department in accordance with MADEP regulations CMR 22.22, a hazard to public water supply exists. All valves and devices shall be at the owner’s expense. All annual and bi-annual inspections will be at the owner’s expense.
- A6.8 Upon repair or installation of water services, all Massachusetts plumbing and electrical codes shall be followed including, but not limited to, applicable electrical grounding procedures.

All applicable Department and Building permits shall be obtained prior to any work performed.

- A6.9 All services, except fire hydrants, shall be metered. An individual meter shall be required for each premises and each separate service connection.
- A6.10 Each new meter shall be purchased and installed by the Department at the customer's expense. The meter shall be of such size and design as reasonably necessary to serve the customer involved. Ownership of the meter shall be in the Department at all times and subject to the provisions of Section 14 hereof. The Department shall be responsible for maintenance of each meter at the Department's expense, except to the extent that the meter is damaged by a willful act or negligence of the customer, wherein, the customer shall be liable for damages. No building that lacks an operating heating system shall be issued a meter. All meters over one (1) inch shall be maintained by the Department at the customer's expense.
- A6.11 No "common" services are allowed, each premise shall have its own service connection to the main pipe with its own associated meter and account.
- A6.12 Water meters shall be installed at a minimum of 12 inches above the floor (maximum of 48 inches) and 12 inches away from walls with sufficient clearance and access for maintaining meter.
- A6.13 All water services installed under floors shall be sleeved with four inch iron from outside the foundation to the meter location.
- A6.14 With the exception of irrigation and outdoor-use meters, secondary sub-meters within a premise will not be installed, maintained or read by the Department. Secondary billing is the sole responsibility of the property owner. Each Town meter shall have its own service from the street.
- A6.15 On any secondary meter for irrigation systems there shall be a tee in the service line before the house meter to be read independently. Two meters will be read and two separate charges generated; one charge for water and one for sewer (if applicable) for the residence and the second bill for irrigation water usage. Outdoor water use shall be subject to the Town's Water Ban Regulations. Water metered for outdoor use shall be charged the Irrigation Rate. Any other arrangement shall be approved only by the Commissioners on an individual basis.
- A6.16 The quantity of water recorded by the meter shall be accepted as conclusive by both the customer and the Department except when the meter has been found to be registering inaccurately, or has ceased to register. In any such case, the quantity may be determined by the average registration of the meter in corresponding past period or by the average registration of the new meter. The method more representative of the conditions existing during the period in question shall be used.
- A6.17 The Department reserves the right to remove and test any meter at any time and to substitute another meter in its place. In the case of a disputed account involving a question as to the accuracy of the meter, such meter will be tested by the Department upon request of the applicant. A fee will be charged for testing such meters. In the event that the meter tested is found to have an error to the detriment of the customer in excess of 2% at any rate

of flow within normal test flow limits, the fee will not be charged and the current bill rendered based on the last reading of such meter shall be corrected accordingly.

- A6.18 Any materials used in repairs made at the meter shall be billed to the property owner.
- A6.19 Requests for additional meter readings shall be subject to a service charge. The charge covers labor reading the meter and calculation of the statement from the reading.
- A6.20 The owner of any premises having a private well or other private water source will not be allowed to run said system within the same structure as the public water supply system or to have a physical connection between the private well system and the public water supply system.

#### **ARTICLE VII - WATER USE RESTRICTIONS**

- A7.1 Water use restrictions shall be enforced as per MADEP Water Management Act Permit
- A7.2 Odd – Even Water Ban shall mean – odd numbers addresses will be permitted to water on Odd numbered days. Even numbered addresses will be permitted to water on even numbered days.

#### **ARTICLE VIII – SEWER, GENERAL**

##### **Authority**

- A8.1 The Department reserves the right to amend these Sewer Regulations in any manner and to establish more stringent limitations or requirements as is deemed necessary or appropriate.
- A8.2 The Department reserves the right to smoke test public and private sewers. Such activity may result in harmless smoke entering homes or visible in the streets though manhole and catch basins.

##### **Right of Entry/Easements**

- A8.3 Duly authorized representatives of the Town shall be permitted to enter all private property through Town owned easements for the purpose of inspection, observation, measurement, sampling, testing, maintenance, repair or reconstruction of any portion of a public sewer system lying within said easement. Inspections conducted pursuant to routine periodic surveys or on a report of a complaint shall be performed at all reasonable times during normal business hours. When the Town reasonably suspects that a violation of these Wastewater Regulations is or may be occurring or an urgent condition or emergency exists that requires immediate action on the part of the Town access shall be permitted at such other times as is necessary for the correction of said violation or abatement of such emergency. All entry and subsequent work, if any, shall be done in full accordance with the terms of said easement. Where a user has security measures in force that would require clearance before entry to the

premises, the user shall make necessary arrangements to permit Town personnel to enter without undue delay for the purpose of carrying out their specific responsibilities.

- A8.4 Easement shall mean an acquired legal right for the specific use of land owned and maintained by others, whether recorded or by prescription.

#### **Use of Sewers**

- A8.5 The use of all public sewers in the Town shall be controlled by the Department. No person shall, without prior authorization from the Department, uncover, excavate over, block access to, make any connection with or opening into, alter, or disturb the Town's wastewater system.
- A8.6 No person shall maliciously, willfully, or negligently break, damage, destroy, uncover, deface or tamper with any structure, appurtenance, or equipment which is part of the Town's wastewater system.
- A8.7 The applicant for any new connection(s) that exceeds 330 gallons per day shall be required to create new capacity or remove/reduce existing flow from the sewer system proportionate to four (4) gallons of sewage for every one (1) gallon anticipated as a result of the new connection or new use. The applicant shall provide documentation to the Department for its approval indicating compliance with the "four-to-one" requirement before the connection permit is issued.

#### **Discharge Limitations**

- A8.8 Requirements and limitations on discharges set by the Massachusetts Department of Environmental Protection ("DEP") shall apply in any case where they are more stringent than federal requirements and limitations or those contained in these Regulations.
- A8.9 No person shall discharge or cause to be discharged any of the following described waters or wastes to any public sewers:
- a) Pollutants which create a fire or explosion hazard at the wastewater treatment facility, including, but not limited to, gasoline, benzene, naphtha, fuel oil or other flammable or explosive liquid, solid or gas, or any wastestream with a closed cup flashpoint less than one hundred forty (140) degrees F.
  - b) Any waters or wastes containing toxic or poisonous solids, liquids or gases in sufficient quantity, either singly or by interaction with other wastes, to injure or interfere with any wastewater treatment process, constitute a hazard to humans or animals, create a public nuisance, or create any hazard in the receiving waters or the wastewater treatment facility.
  - c) Solid or viscous substances in quantities or of such size capable of causing obstruction to the flow in sewers, or other interference with the proper operation of wastewater works such as, but not limited to, ashes, cinders, sand, mud, straw, shavings, metal, glass, rags, feathers, tar, plastics, wood, unground garbage, whole blood, paunch manure, hair, entrails, wipes (including "flushable" wipes), and paper or plastic dishes, cups, milk containers, etc., whether whole or ground by garbage grinders.
  - d) Any septage wastes from cesspools, privies, tight tanks, septic tanks, distribution boxes, or holding tanks.
  - e) Non-biodegradable cutting oils, materials of mineral oil origin or petroleum oil in amounts that will cause interference or pass through. Any trucked or hauled wastes

discharged at a non-approved discharge point. This shall include wastes from recreational vehicles, campers, trailers and mobile homes.

- A8.10 Waste grease and oil shall not be discharged to the sanitary sewer. All waste grease and oil must be collected in an appropriate container provided by a Board of Health approved vendor and stored in a location approved by the Board of Health on the premise. The container must be stored on an impervious surface. Containers must be capable of being sealed or be stored in a sheltered area to prevent entry of precipitation and vermin. The removal, transport and disposal of fats, oils and grease shall be performed by a septage/offensive substances hauler.
- A8.11 Downspouts, roof drains and footing drains shall not be connected to public sanitary sewer. Private property sump pumps installed to manage groundwater or other storm water shall be permanently connected to the drainage system or discharge onto the ground and shall not include any valving or other connections that can be used to alter the discharge path. Discharge from downspouts, roof drains, footing drains and sump pumps shall not discharge onto Town property or into the right of way.
- A8.12 No person shall discharge or cause to be discharged any stormwater, surface water, groundwater, roof runoff, subsurface drainage, uncontaminated cooling water, or unpolluted industrial process waters to any sanitary sewer. Such discharges are herein referred to as "inflow" sources.
- A8.13 Homeowners shall be responsible for maintaining their private connection to the public sanitary sewer and ensure that groundwater does not infiltrate into the service through cracks or other defects.
- A8.14 Stormwater and all other unpolluted drainage shall be discharged to such sewers as are specifically designated as storm sewers (drainage), or to a natural outlet approved by the Department.
- A8.15 Upon identification of private downspouts, roof drains, footing drains or sump pumps which are found to be connected to the public sanitary sewer, or the instance of groundwater infiltration into the private sewer service, the Department shall issue a notice to the homeowner/resident advising of the required action to disconnect the inflow/infiltration source. The escalation of notice for inflow/infiltration source shall include:
- a. First notice: Written letter to homeowner/resident notifying discovery of inflow/infiltration source and advising of required schedule for disconnection. This letter shall indicate the estimated volume of inflow/infiltration discharged to the public sanitary sewer per day and the basis of such estimation. Homeowner/resident shall be required to disconnect inflow/infiltration source and redirect appropriately within three (3) months of notice. A written attestation of inflow/infiltration source removal or repair, including the specific action and location of redirection shall be provided to the Department. The Department shall be permitted to inspect and confirm the repair/action.
  - b. Second notice: If inflow/infiltration source has not been appropriately removed or repaired within three (3) months of first notice date, the Department shall provide a second notice advising that the homeowner/resident's sewer use bill shall be amended to include additional charges for discharge of inflow/infiltration. Inflow/infiltration charges shall be billed in the following manner:
    - i.  $[\text{Estimate of inflow/infiltration volume (gallons per day)}] * [\text{Number of days in quarterly billing cycle}] * [\text{Town's current sewer rate (\$)}] * [\text{Inflow/infiltration charge multiplier}] = \text{Quarterly inflow/infiltration charge}$

- ii. The Inflow/infiltration charge multiplier shall be one (1) through the first four (4) quarters of inflow/infiltration charge billing. After one year of inflow/infiltration charge billing, the multiplier shall increase to two (2), and henceforth shall increase by one (1) each year on the anniversary of the second notice.

### **On-Site Systems (Septic Tank/ Cesspool)**

- A8.16 The abandonment of the septic system shall be in conformance with the State Sanitary Code (Title 5, septic tank, distribution box, leaching pit, cesspools) and the leaching gallery, if necessary, shall be pumped clean by a licensed septic hauler. All structures shall be destroyed and collapsed after pumping. Clean gravel will be used for backfilling the structures and properly compacted. The Board of Health is to be provided at least 48 hours written notice of system abandonment (tie-in). If available, the Health Agent will perform a site visit during the abandonment process.
- A8.17 All tanks, cesspools, septic tanks, etc. are considered part of the building and should be hooked up in entirety except upon special determination of the Board of Health, or unless otherwise allowed by the Board.

### **ARTICLE IX – SEWER, CONSTRUCTION METHODS**

- A9.1 Construction methods and materials shall conform to the specifications outlined in Appendix A “*Town of Medway Specification for Laying Public Sewers, Building Sewers and Manholes*”. The size, slope, alignment and materials of construction of a sewer, and the methods to be used in the excavating, placing of the pipe, jointing, testing, and backfilling shall all conform to the requirements of the attached Appendix A “*Town of Medway Specification for Laying Public Sewers, Building Sewers and Manholes*”, the building and plumbing codes, and other applicable rules and regulations of the Town.
- A9.2 PVC pipe shall not be installed in the winter months when the temperature is below 30 degrees. No frozen material shall be used for backfill.
- A9.3 DIG SAFE shall be called before beginning work. The Department shall be notified with the DIG SAFE Request Number.
- A9.4 As-built inverts, slopes and stations shall conform to the approved definitive plan. Any changes shall be explained in writing prior to the proposal being considered for approval.

### **Mainline (gravity)**

- A9.5 Any and all offsets (change in direction) of pipe on Town systems shall include a manhole at said offset.
- A9.6 The private installation of a sewer which is intended to become a public sewer shall be installed only upon obtaining a permit from the Department. Prior to the issuance of any such permit, the applicant is required to submit design drawings and specifications of the proposed sewer for considerations, recommendations, and approval. The Department may, in its sole discretion, submit the said design information to its independent professional engineering firm for review. The applicant shall be required to pay the full cost of any such engineering review. The said payment shall be made by the applicant to the Town of

Medway. The Department shall not approve, disapprove or otherwise act on said application until payment has been made.

- A9.7 No public sewer, sewer located in or on a public way or public property, or a sewer intended to become a public sewer shall incorporate any mechanical, hydraulic or other means to lift sewage and/or wastewater in order to provide for flow. All such sewers shall provide for gravity flow of all sewage and/or wastewater.
- A9.8 Upon appropriate request, the Department may grant an exception of requirements to the prior section after a public hearing and notice to the Board of Health, the Town of Medway Planning Board, and any other interested parties. In acting on any such request the Board shall consider the number of potential buildings to be serviced, the topography of the area involved, any alternative means of sewage disposal, and any claimed extenuating circumstances advanced by the applicant. In granting any such exception the Department shall impose as a condition of such grant that any costs and expenses of operation, maintenance and replacement shall be paid for solely by the owners of the real property serviced by the sewer.
- A9.9 A sewer main shall be designed to service the maximum building area at a depth sufficient to provide full basement service. The minimum allowable cover on a sewer main is 5 feet. Any deviation from this must be approved in writing by the Department.

#### **Service Connection**

- A9.10 Sewer services to buildings where water is supplied by a private well shall have a meter on the well. The meter shall be installed on the building plumbing such that it captures all flow volumes to Town sewer system. Installation specifications shall be approved by Department prior to any work being performed. The property owner will arrange for the provision of the meter with the Department. The meter will then be maintained and read by the Department.
- A9.11 When a connection to the Town's sewer system will involve a pumping system, the following additional requirements shall apply:
- a. The Department will be provided with three (3) copies of a plan and specifications for the pumping system, force main, terminal manhole and overflow structured stamped by a Professional Engineer. This plan will have to be approved by the Department prior to the construction of the system.
  - b. The pumping system shall conform to the specifications outlined in Appendix A "*Town of Medway Specification for Laying Public Sewers, Building Sewers and Manholes*".

#### **Manholes**

- A9.12 Sewer manholes shall conform to the Specification outlined in Appendix A "*Town of Medway Specification for Laying Public Sewers, Building Sewers and Manholes*", or project specific Construction Specifications and Details.

## **ARTICLE X - PAYMENT FOR SERVICE**

- A10.1 Bills for service will be rendered periodically in accordance with the Term of Payment noted on the applicable Rate Schedules and are payable at the office of the Town Treasurer/Collector upon presentation.
- A10.2 Each bill for service will be rendered to the customer of record except where a special agreement has been made. In all cases, the owner of record will be held responsible for the payment of the bill.
- A10.3 New property owners are responsible for notifying the Department, in writing, within 15 days of transfer of property ownership including their contact information to allow correspondence and billing in a timely manner.
- A10.4 Bills not paid within thirty (30) days of the date of issue shall be subject to demand and interest charges. Accounts outstanding as of June 30<sup>th</sup> of the prior fiscal year will be added to the real estate tax bill as a lien.
- A10.5 Requests for "Final Readings" shall be issued as a Billing Record and an administration fee will be reflected on the final bill for the property. It is the property owner's responsibility to notify the Department in writing when selling a property to allow a minimum of 3 business days or 72 hours for the process of a final bill.
- A10.6 Requests for abatements on water/sewer billings are accepted for thirty (30) days from the date of issue of the bill. Account must be current in order to file an abatement request.
- A10.7 A charge will be made each time for the turning on or off of the service by the Department when requested by the owner or tenant. Whenever a customer desires to have the water service discontinued, the customer shall notify the Department. Until such notice is received by the Department, the customer shall be responsible for payment for service rendered by the Department. A reasonable time after the receipt of such notice shall be allowed by the Department to take a reading of the meter and to discontinue service. The owner or agent of the owner must be present any time water service is turned on or off at a property.

## **ARTICLE XI - FEES**

See Current Fee Schedule

**APPENDIX A**  
**SPECIFICATIONS FOR LAYING PUBLIC SEWERS,**  
**BUILDING SEWERS, AND MANHOLES**

**Updated: September 2020**

**MATERIALS**

**1. PIPES**

Polyvinyl Chloride (PVC), without approval from the Department for other, is the only type of pipe that may be used. Pipes shall conform to the following specifications:

**A. Gravity Sewers**

The PVC pipe and fittings shall conform the American Society of Testing and Materials (ASTM) Standard specifications for Type PSM PVC Sewer Pipe and Fittings, Designation ASTM D3034 latest revision. The pipe shall have a maximum pipe diameter to wall thickness ratio (SDR) of 35, without written approval from the Department for other. The pipe shall be tested by the flat plate deflection method at a minimum of 45 psi at 5 percent deflection in accordance with ASTM D2412.

**B. Pressure Sewers**

PVC pressure pipe shall be rated a maximum of SDR 21, without written approval from the Department for other, pressure rated 200 psi with a factor of safety of 2.5 with integral thickened wall bells. Pipe shall be made from clean, virgin approved Class 12454-B PVC compound conforming to ASTM resin specification D1784. The pipe shall be delivered in standard 20-foot lengths.

**C. Service Connections**

Six-inch (6") PVC SDR-35 (ASTM D3034) must be used up to 10 feet from the building. All materials and workmanship within 10 feet of a building foundation shall conform to current Massachusetts plumbing code.

Sewer Service shall be a minimum of 10 feet off building if pipe runs parallel to the building structure. If the entire length of the service must be less than 10 feet, pipe shall be cast iron or PVC Schedule 40 to a point of 10 feet beyond building.

**2. CRUSHED STONE**

Crushed stone bedding shall be 3/4-inch in size consisting of acceptably clean stone fragments, crushed from hard durable stone, and washed or screened as required. The crushed stone bedding shall be free from lumps of clay, organic matter, frozen material, construction debris, or other objectionable material, and shall have reasonable even gradation from coarse to fine, in accordance with the Massachusetts

Highway Department Standard Specifications for Highways and Bridges specification for Aggregates and related materials M2.010 (Sect. 230.61)

### **3. BACKFILL MATERIAL**

Suitable material for trench backfill above the crushed stone shall be material excavated during the course of construction, but excluding debris, pieces of pavement, frozen material, organic matter, top soil, all wet or soft muck, peat or clay, ledge excavation and rocks over six (6) inches in largest dimensions, or any material which, as determined by the Department, will not provide sufficient support or maintain the completed construction in a stable condition. In certain instances, control density fill (CDF) or other backfill material as determined by the Department, may be required. Placement of backfill material shall include the working of material to achieve suitable moisture content and compaction to the specified density, in accordance with Massachusetts Highway Department Standard Specifications (Spec. 150.60, backfilling for structures and pipes.)

### **4. SEWER CLEANOUT FRAME AND COVER**

The sewer cleanout frame shall be, as a minimum, approximately eight (8) inches inside diameter, ten (10) inches outside at the top with an inside lip of nine (9) inches, and eleven and one-half (11-1/2) inches at the bottom. It shall have an outside flange at the base for stability that protrudes out one (1) inch from the side of the frame in all directions. The cover shall be clearly marked "SEWER" and shall be approximately eight (8) inches in diameter and two (2) inches deep. The frame and cover shall weigh at least fifty (50) pounds.

### **5. MANHOLES**

Sewer manholes shall conform to project-specific Construction Specifications and Details, or as specified herein.

A sewer manhole will be required at a maximum distance of 300 feet on a sewer main or 150 feet on a service.

- A. All precast concrete manholes shall conform to the ASTM "Specifications for Precast Reinforced Concrete Manhole Sections," Designation D478. The barrel shall be at least forty-eight (48) inches inside diameter with a minimum wall thickness of five (5) inches. The outside of the manholes shall be coated with bituminous damp proofing. Segment flanges or joints shall be sealed with approved "gasket" material.
- B. All perforations, whether complete or partial, shall be repaired, filled, with non-shrinking grout and sealed with bituminous damp proofing prior to backfilling.
- C. Manhole steps **will not be allowed.**
- D. Manhole frames and covers shall be at least Class 25 conforming to ASTM "Standard Specification for Gray Iron Castings," Designation: A48. Manhole frames shall have as a minimum, a clear opening of twenty-six (26) inches. The surface of the cover shall have a pattern with the word "SEWER" cast thereon for sanitary sewers, as manufactured by EJCO #2111A, or equal, and as listed in Detail S-02. The frame and cover shall be watertight up to fifteen (15) psi external pressure.

- E. Elevations of less than twelve (12) inches from the precast concrete manhole and the roadway shall be accomplished with red clay sewer brick and mortar or other means, as determined by the Department. Elevations greater than twelve (12) inches shall be made with precast concrete riser rings, designed for that purpose.
- F. All inverts in sewer manholes shall be solid red sewer brick (Type SS) with a brick table to the top the pipe.

## **PIPE INSTALLATION**

### **1. PIPE DIAMETER**

- A. The minimum interior pipe diameters for gravity building sewers and public sewers shall be six (6) and eight (8) inches, respectively.

### **2. PREPARATION OF PIPE**

All pipes and fittings shall be carefully inspected before being laid and no cracked, broken or defective pipe or fittings shall be used in the work. The ends of the pipe shall be cleaned with a brush, washed and thoroughly scrubbed where necessary to remove dirt or other foreign material. Care shall be exercised to ensure that the inside surfaces of the bell are smooth and free from any projections which would interfere with the assembly of water tightness of the joint.

### **3. HANDLING PIPE**

Pipe shall be handled in an approved manner, using slings or other approved devices. No pipe shall be dropped from trucks or into trenches.

### **4. LAYING PIPE**

- A. Pipe shall be laid accurately to line and grade on a minimum of six (6) inches of bedding (crushed stone) in earth, and a minimum of twelve (12) inches of bedding in rock, measured below the outside of the pipe barrel. Crushed stone shall extend up to a point six (6) inches above the pipe. The stone shall be placed in layers not over six (6) inches thick, and each layer shall be thoroughly compacted by tamping and chinking on each side of pipe to provide uniform support. Impervious material may be required on service connections for a distance ten (10) feet from the inside wall of the foundation to where crushed stone can start. The first foot of stone over the pipe shall be filled by hand.
- B. Pipe shall be laid with the spigot end pointing in the direction of the flow.
- C. Joints shall be in accordance with approved factory recommendations. Cement mortar joints will not be permitted. Joints for PVC shall conform to ASTM D3212. Transitions between different pipe sizes shall be accomplished by using flexible eccentric reducing couplings with stainless steel bands equal to "Fernco" couplings.
- D. Completed pipelines shall be free of deviations from grade. Visible leaks, broken pipes, etc., shall be repaired or replaced.
- E. Pipe shall be laid during regular operating hours of the Medway Department of Public Works unless otherwise approved by the Department.

- F. Provisions shall be made for plugging with a watertight plug at night or when work is suspended. Sewers shall not be used to carry groundwater from the trench (dewater). The Contractor shall keep all debris; and other material from entering sewers. Contractor shall clean the area on a daily basis and remove all debris, equipment and excess material at the completion of the work, in that area.
- G. Sewers shall be located at least ten (10) feet horizontally from existing water mains, where possible. If it is not possible for absolutely essential reasons, to achieve such separation, then the sewer may be located not less than three (3) feet from a water main, horizontally, provided where possible there is at least eighteen (18) inches vertical separation between the bottom of the water main and the top of the sewer, with the sewer below the water main. When it is impossible to obtain the required separation, the sewer shall be constructed of mechanical joint pipe, or as approved by the Department. Any sewer located within six (6) feet of a water pipe shall be constructed of mechanical joint ductile iron, or other, as approved by the Department.
- H. The size, slope and alignment of the sewer shall be subject to the approval of the Department. All sewer mains shall be installed using laser to ensure correct grade and line. The installer shall check the elevation of the top of each length of PVC pipe laid at each end and at the midpoint. The midpoint elevation shall be within 0.01 foot of the average of the two ends. The slope of the building sewer shall not be less than one-quarter (1/4) inch per foot, except where approved by the Department.
- I. At any bend greater than 30 degrees, a PVC or cast iron "Y" clean out shall be provided upstream from the bend. The clean out shall be cast iron if it is located in a driveway. A "Y" branch shall be used within a section of pipe and access shall be within 6 inches of ground surface surrounded by stone. Tracer material shall be used for future ease of cleanout location.
- J. Pipe shall be placed in accordance with the attached Typical Trench Detail. Whenever necessary to prevent caving during excavation in gravel, sandy soil, or other unstable material, the trench shall be adequately sheeted and braced. Failure to comply with proper applicable OSHA standards with regard to; sheeting, shoring, or bracing shall be cause for a Notice of Violation. All sheeting, shoring and bracing of trenches shall conform to those standard requirements.
- K. Compaction of trenches beneath roadways shall be done using methods approved by the Department. The minimum degree of compaction throughout the trench shall be ninety-two (92) percent. Compaction tests will be performed where directed by the Department, at the expense of the applicant.
- L. The connection of the building sewer to the public sewer shall be made at the "Y" branch, if such branch is available at a suitable location. If no branch is available, a connection may be made by tapping the public sewer by a method approved by the Department, then inserting an approved cast iron, ductile iron, stainless steel or PVC "Y" or "T" saddle with stainless steel mounting bands or other approved connection device. Cutting a hole in the public sewer by hand is prohibited. Building sewers must have a "Y" cleanout located ten (10) feet from the building's exterior wall.
- M. No sewer service connections to be installed into manholes and/or consist of "inside drops" without the written approval of the Department.

- N. The sewer service shall service the complete building. The pipe shall be accessible in order for it to be relocated one foot below the cellar floor when necessary. The minimum slope for all pipes is 2%, unless otherwise approved by the Department.
- O. New sewer services shall be connected to the existing public mainline sewer with an Inserta Tee®. Any deviation from this must be approved in writing by the Department.
- P. Where a factory tap is not available to connect the sewer service, coring of the sewer mainline shall conform to Inserta Tee® specifications with a 6.5" saw. New developments shall replace pipe length and connect through a factory wye.
- Q. Care shall be taken with service connections so that no stones or gravel enter the system.
- R. When water is present in a trench, a sump of crushed stone shall be constructed, and water shall be pumped at all times. The trench shall be kept dry at all times during construction. When actual pipe installation is not in progress, the open ends of the pipe shall be closed with temporary watertight plugs or by other approved means. All joints and connections shall be made watertight and gastight.
- S. Prior to final acceptance, the entire line shall be pressure tested, cleaned and water-jetted to remove rocks and debris and that the Department may require a visual or CCTV inspection be accomplished prior to acceptance. At the manhole downstream of each section being cleaned, the effluent line shall be plugged and all rocks, debris and water shall be removed and disposed of by the Contractor.
- T. Rapid changes in elevation of mainline sewer greater than two (2) feet are to be made at interior drop manholes or as approved by the Department.
- U. Changes in elevation for service laterals are to be made with vertical extensions (chimneys). Vertical extensions (chimneys) under ten (10) feet, may be made with PVC or other approved pipe(s) and fittings. Vertical extensions (chimneys) over ten (10) feet deep will require that tees and/or wyes affixed to the main line shall be of ductile iron, with mechanical joints, or other as approved by the Department. In either case, the vertical extensions (chimneys), may be of PVC and supported and protected by a surrounding layer of crushed stone the length/height of the pipe. The vertical stone shall be held in place by mechanical means (e.g.: "Sono Tube"), or as approved by Department.
- V. If the visual inspection of the completed sewer or any part thereof shows any pipe, manhole or joint which allows infiltration of water in noticeable stream or jet, the defective work or material, the problem area shall be replaced or repaired as directed.

#### **5. LOW PRESSURE/PRIVATE PUMPING SYSTEMS**

- A. Low pressure/Private pumping systems will only be approved when a gravity connection is not feasible.
- B. The pumping equipment shall be a duplex system suitable for handling raw sanitary wastewater (pass 2-inch solids) and be provided with on/off high-water alarm controls.
- C. Stand by power or a 1,000-gallon capacity emergency storage tank will be required.

- D. The force main shall terminate in a manhole structure (transition manhole) which will be located on the property adjacent to the Town sewer. The transition manhole shall be constructed in accordance with the requirements listed within this appendix and the Rules & Regulations.
- E. The gravity sewer connection from the transition manhole to the Town sewer will be installed in accordance with the requirements listed within this appendix and the Rules & Regulations.

**TESTING OF PUBLIC SEWER:**

**1. MAINLINE (GRAVITY)**

After completing installation and backfill of sewer pipe to the satisfaction of the Department, the applicant shall, at his expense, conduct a line acceptance test under the following procedures:

- A. After a manhole-to-manhole reach of pipe has been backfilled and cleaned, the service connections shall be capped and pneumatic plugs shall be placed in the line at each manhole and inflated to twenty-five (25) pounds per square inch gauge (psig), or as recommended by the manufacturer. Low-pressure air shall be introduced into this sealed line until the internal air pressure reaches four (4) psig greater than the average backpressure of any groundwater that may be over the pipe. At least two (2) minutes shall be allowed for the air pressure to stabilize.

After the stabilization period (4 psig minimum pressure in the pipe), the air hose from the control panel to the air supply shall be disconnected. The portion of line being tested shall be termed "Acceptable" if the time required in minutes for the pressure to decrease from 3.5 to 2.5 psig (greater than the average back pressure of any groundwater that may be over the pipe) shall not be less than the time shown for the given diameters in the "**Sewer Air Pressure & Mandrel Testing Form**" included herein.

- B. In areas where groundwater is known to exist, the Contractor shall install a 1/2-inch diameter capped pipe nipple, approximately 10-inches long, through the manhole wall adjacent to one of the sewer lines entering the manhole. This shall be done at the time the line is installed. Immediately prior to the performance of the Line Acceptance Test, the groundwater shall be determined by removing the pipe cap, blowing air through the pipe nipple into the ground so as to clear it, and then connecting a clear plastic tube to the nipple. The hose shall be held vertically and a measurement of the height in feet of water over the invert of the pipe shall be taken after the water has stopped rising in this plastic tube. The height in feet shall be divided by 2.3 to establish the pounds of pressure that will be added to all readings. (For example, if the height of water is 11-1/2 feet, then the added pressure will be 5 psig. This increases the 3.5 psig to 8.5 psig, and the 2.5 psig to 7.5 psig. The allowable drop of one pound and the timing remain the same). In no case shall the starting pressure exceed 9.0 psig.

Groundwater Height (ft)	Additional Pressure (psig)
1	0.50
2	1.00
3	1.50
4	2.00
5	2.00
6	2.50

Groundwater Height (ft)	Additional Pressure (psig)
7	3.00
8	3.50
9	4.00
10	4.50
11	5.00
12	5.00

## 2. PRESSURE (FORCE MAIN)

Once the pipeline section has been filled with clean water at normal pressure, all entrapped air removed and disconnected from water supply, the pressure shall be raised to at least fifty percent (50%) above the normal working pressure. A special pressure pump shall take water from a small tank of proper dimension to satisfactorily measure the rate of pumpage into the pipeline. This pressure shall be maintained for a minimum of sixty (60) minutes, during which time the line shall be checked for leaks by the inspector. Measured rate of water leakage shall not exceed the values given in the following table:

### Allowable Leakage per 1.000 feet or 50 joints

Pipe Diameter (Inches)	(Gallons/Hour)
4	0.27
6	0.41
8	0.54
10	0.68
12	0.81

*\*testing of pipe diameters not indicated above shall be subject to approval by the Department.*

If the section of sewer fails to pass the leakage and/or pressure tests, the Contractor shall locate, uncover and repair or replace the defective pipe fitting or joint and retest all at his own expense. Pipe shall be accepted only when the leakage does not exceed the above standards. Approval does not absolve the Contractor from his responsibility if leaks develop later within the period of warranty.

## 3. MANHOLES

- A. Leakage tests shall be made and observed by a representative of the Department and the contractor on each manhole.
- B. After the manhole has been assembled in place, all lifting holes shall be filled and pointed with an approved non-shrinking grout and sealed with bituminous damp proofing prior to backfilling. The test shall be made prior to placing the shelf and invert. If the groundwater table has been allowed to rise above the bottom of the manhole, it shall be lowered for the duration of the test. All pipes and other openings into the manhole shall be suitable plugged.
- C. The manhole shall then be filled with water to the top of the cone section. If the excavation has not been backfilled and observation indicates no visible leakage, that is no water visibly moving

down the surface of the manhole, then the manhole may be considered to be satisfactorily watertight. If the test described above is unsatisfactory to the Department's representative, or if the manhole excavation has been backfilled, then the test shall be continued. A period of time may be permitted in the Contractor so wishes to allow for absorption. At the end of this period, the manhole shall be refilled to the top of the cone. After two (2) hours, the manhole shall be refilled to the top of the cone. This amount shall be extrapolated to a 24-hour rate and the leakage determined on the basis of depth. The leakage for each manhole shall not exceed one (1) gallon per vertical foot for a 24-hour period. If the manhole fails this requirement, the manhole will be deemed to have failed the test. It shall then be the Contractor's responsibility to uncover the manhole as necessary and to disassemble, reconstruct and replace it. The manhole shall then be retested and, if satisfactory, all interior joints and those exterior joints within six (6) feet of the surface shall be filled and pointed and sealed with bituminous damp proofing prior to backfilling.

- D. The test may be conducted either before or after backfilling around the manhole. However, if the Contractor elects to backfill prior to testing, for any reason, it shall be at his own risk and it shall be incumbent upon the Contractor to determine the reason for any failure of the test. No adjustment in the leakage allowance made for unknown causes such as leaking plugs, absorption, etc.; i.e., it will be assumed that all loss of water during the test is a result of leaks through the joints or through the concrete. Furthermore, the Contractor shall take any steps necessary to insure that the water table is below the bottom of the manhole throughout the test.
- E. If the groundwater table is above the highest joint in the manhole, and if there is no leakage into the manhole as determined by the Department's representative, such a test can be used to evaluate the water-tightness of the manhole. However, if the Department's representative is not satisfied, the Contractor shall lower the water table and carry out the test as described herein above.
- F. Leakage tests for four (4) foot diameter manholes may be made using vacuum testing equipment. This type of test may be used only immediately after assembly of the manhole and only prior to backfilling. The manhole to pipe connection should only be a flexible connector. All lift holes shall be plugged with a non-shrinking mortar and sealed with bituminous damp proofing prior to backfilling. For this test, each four (4) or five (5) foot diameter manhole shall be tested under ten (10) inches of Hg vacuum. The test shall pass if the vacuum remains at ten (10) inches of Hg or drops no lower than nine (9) inches of Hg after sixty (60) seconds for manholes zero (0) to ten (10) feet deep, seventy-five (75) seconds for manholes ten (10) to fifteen (15) feet deep or ninety (90) seconds for manhole fifteen (15) to twenty-five (25) feet deep.
- G. All excess material including dirt, loose concrete, bricks, grit, stones and any other material, shall be removed from all manholes prior to final acceptance by the Department's representative.

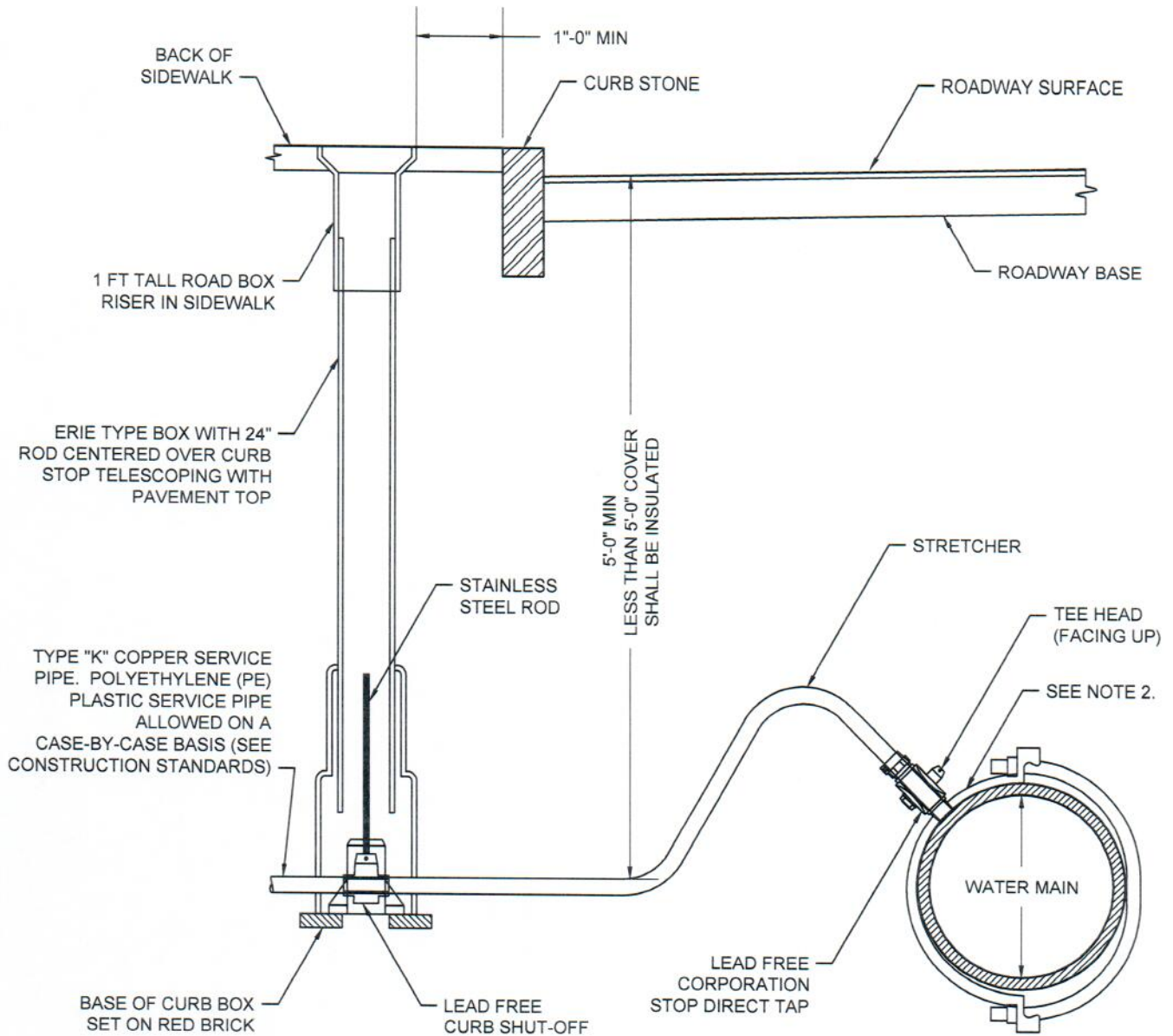

NOT TO SCALE

**NOTES:**

1. ALL SERVICE CONNECTIONS AND APPURTENANT VALVES AND FITTINGS SHALL BE LEAD FREE.
2. FOR WATER MAINS UP TO AND INCLUDING 8-INCH DIAMETER USE SADDLE CONNECTION IF SERVICE LARGER THAN 1" DIAMETER, ALL PLASTIC MAINS SHALL BE TAPPED USING A SADDLE CONNECTION.



Town of **MEDWAY**  
DEPARTMENT OF PUBLIC SERVICES

**TYPICAL WATER CONNECTION  
FOR 1"-2" SERVICE**

DATE:  
APRIL 2021  
REV:  
0

DETAIL NO.  
**W-01**

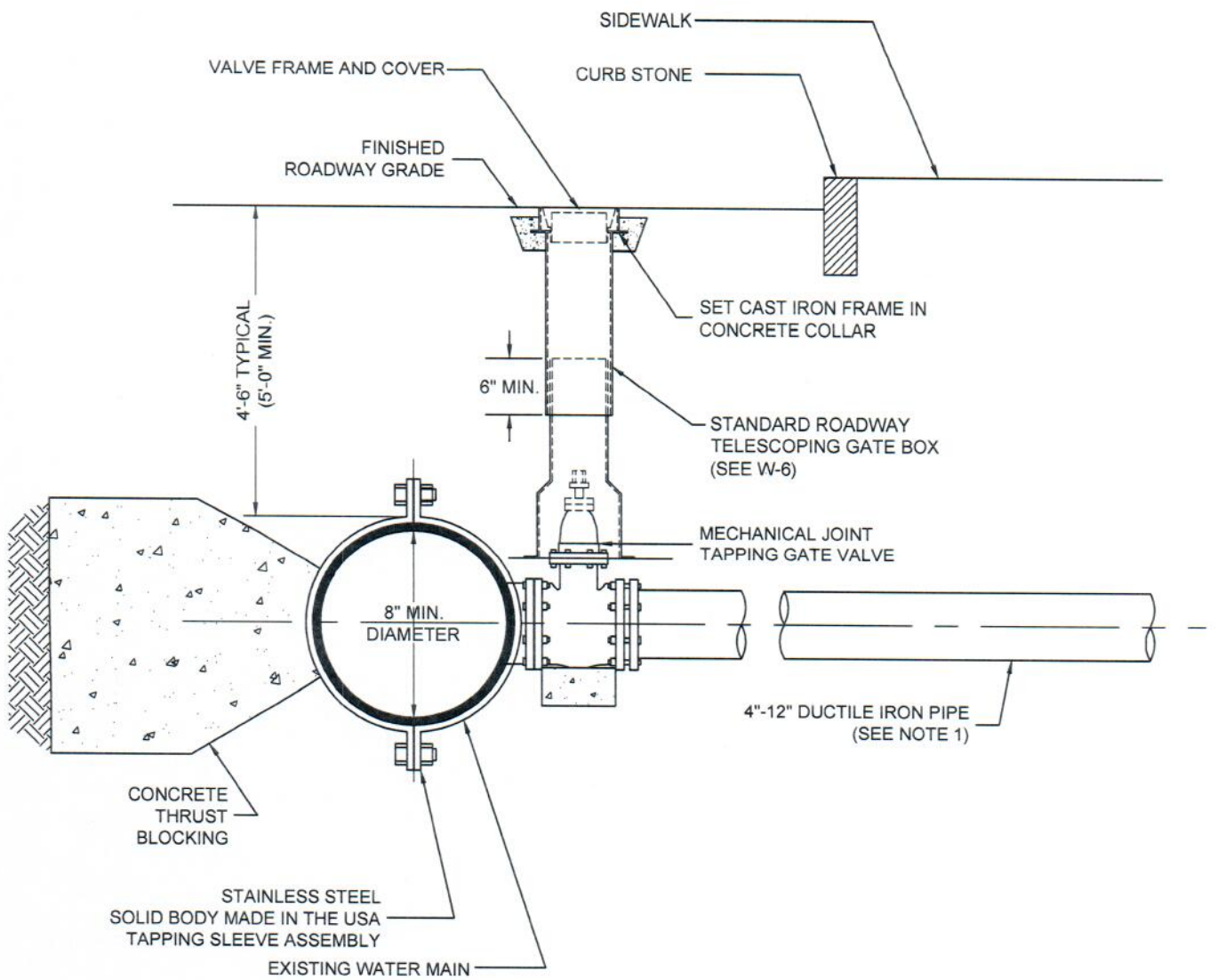

NOT TO SCALE

**NOTES:**

1. MAXIMUM TAPPING SLEEVE SHALL NOT BE GREATER THAN  $\frac{1}{2}$  DIAMETER OF CONNECTING MAIN.
2. MECHANICAL JOINT RESTRAINTS AND GASKETS ON ALL MECHANICAL JOINTS.
3. TOWN MAY REQUIRE THREADED ROD AS RESTRAINT.



Town of **MEDWAY**  
DEPARTMENT OF PUBLIC SERVICES

**TYPICAL CONNECTION  
(TAPPING SLEEVE)**

DATE:  
APRIL 2021  
REV:  
0

DETAIL NO.  
**W-02**

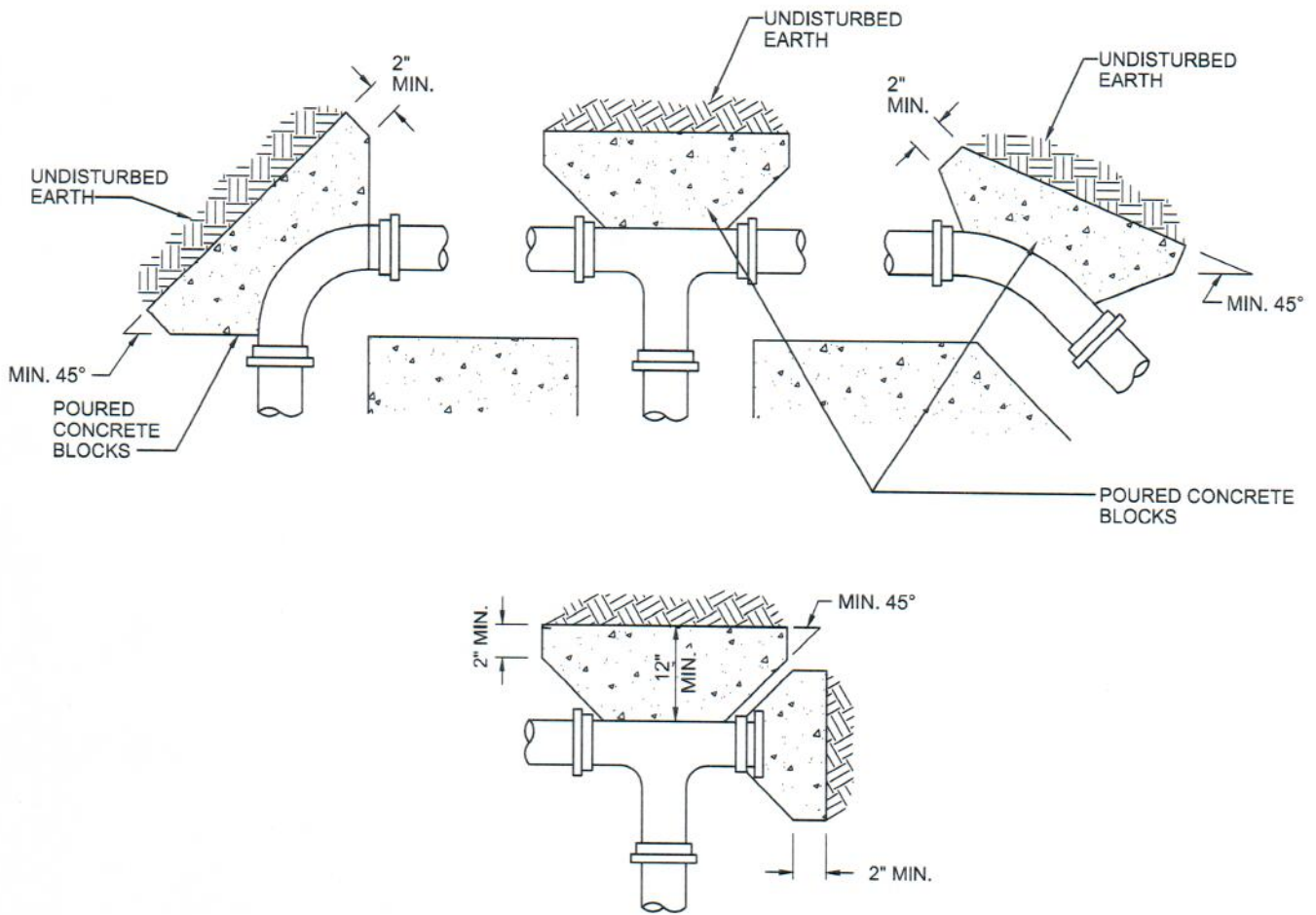

**PLAN VIEWS**

NOT TO SCALE

**NOTES:**

1. SPECIFIC THRUST BLOCK DESIGN SHALL CONFORM TO AWWA GUIDELINES.
2. PLACE 4 mil. POLYETHYLENE BETWEEN CONCRETE AND FITTING (CONCRETE SHALL NOT INTERFERE WITH JOINT).
3. MINIMUM CONCRETE THICKNESS SHALL BE 12 INCHES.
4. THRUST BLOCK ORIENTATION SHALL BE SUCH THAT THE CENTER OF THE FITTING CORRESPONDS WITH THE CENTER OF THE THRUST BLOCK.
5. THE MINIMUM ALLOWABLE ANGLE (EITHER VERTICAL OR HORIZONTAL) SHALL BE 45 DEGREES.



Town of **MEDWAY**  
DEPARTMENT OF PUBLIC SERVICES

**TYPICAL THRUST  
BLOCK DETAIL**

DATE:  
JULY 2016  
REV:  
0

DETAIL NO.  
**W-03**

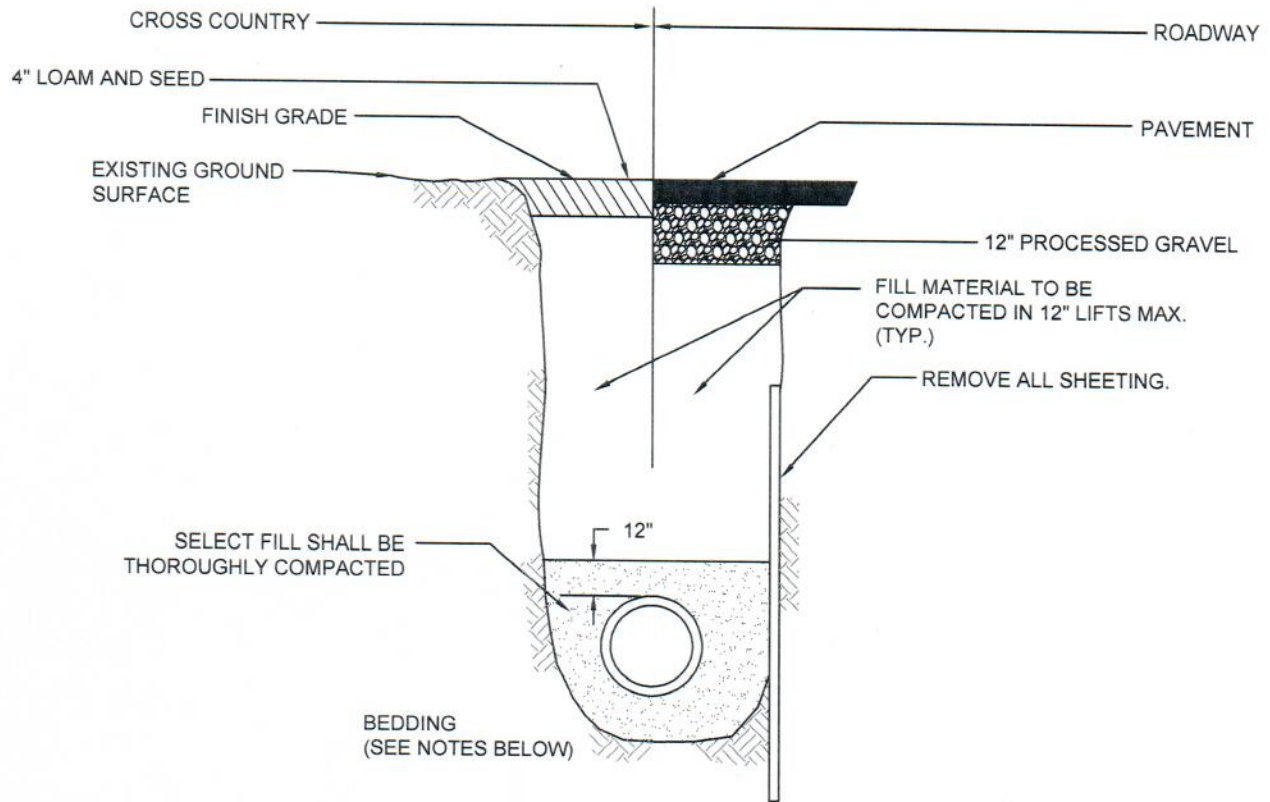

NOT TO SCALE

**NOTES:**

1. TOWN OF MEDWAY MAY REQUIRE FLOWABLE FILL AT ITS DISCRETION.
2. FOR LOCATIONS WHERE LEDGE IS NOT ENCOUNTERED IN TRENCH, PIPE CAN LAY ON UNDISTURBED EARTH, OR ON SAND BEDDING CONSISTENT WITH AWWA GUIDELINES.
3. FOR LOCATIONS WHERE LEDGE IS ENCOUNTERED, SAND BEDDING SHALL BE MINIMUM OF 12" THICK UNDER PIPE.
4. FILL MATERIAL SHALL BE COMPACTED TO 95% PROCTOR DENSITY.
5. WATER MAIN SHALL HAVE 5'-0" MINIMUM COVER. LESS THAN 5'-0" OF COVER SHALL BE INSULATED.
6. LEDGE SHALL BE REMOVED 12 INCHES AROUND PIPE.



Town of **MEDWAY**  
DEPARTMENT OF PUBLIC SERVICES

**WATER MAIN TRENCH DETAIL**

DATE:  
APRIL 2021  
REV:  
0

DETAIL NO.  
**W-04**

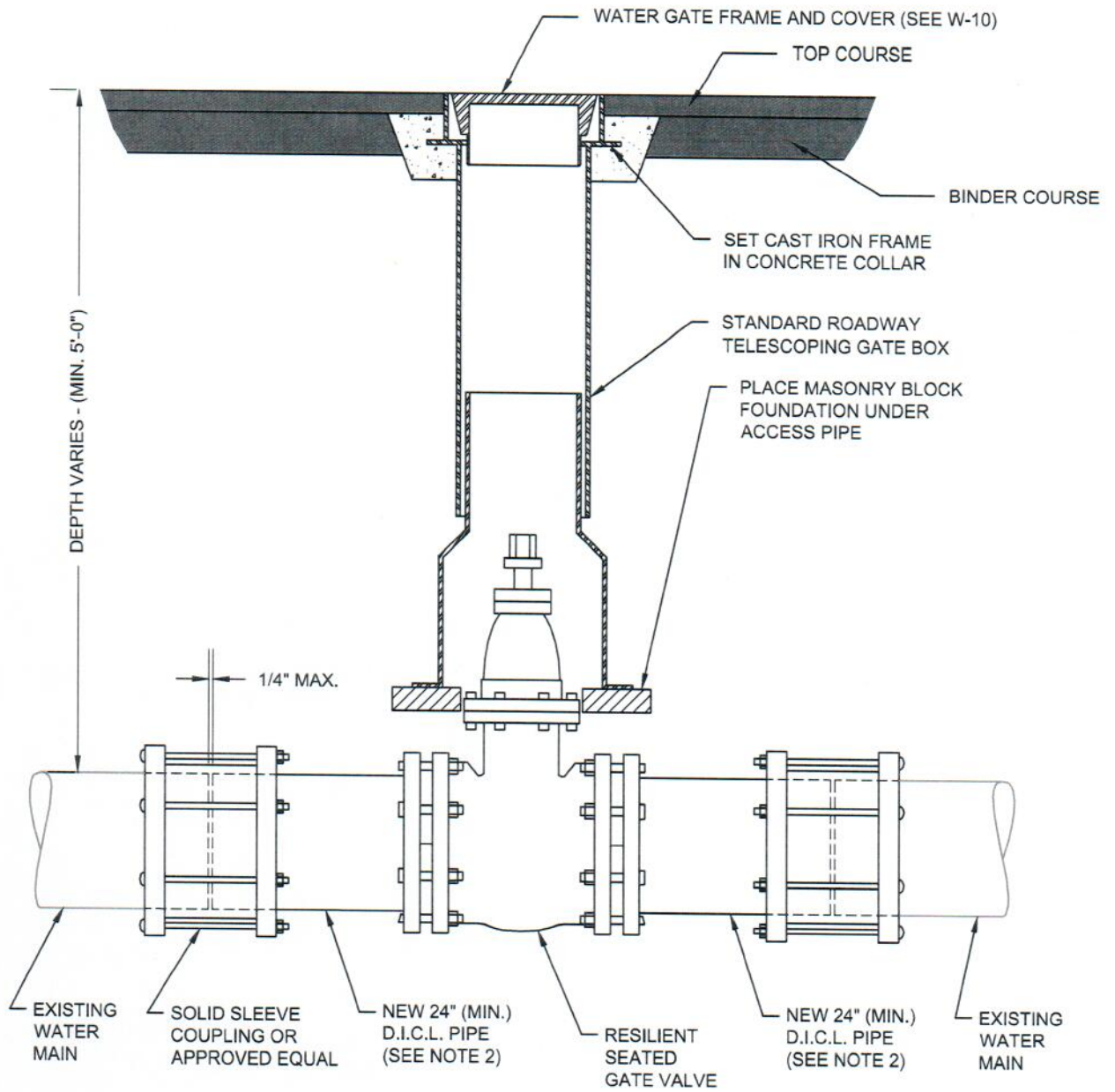

NOT TO SCALE

**NOTES:**

1. ALL EXCAVATION, BACKFILLING AND PAVING SHALL BE IN ACCORDANCE WITH THE TOWN OF MEDWAY REQUIREMENTS.
2. TO THE EXTENT PRACTICAL, VALVE TO BE INSTALLED DIRECTLY TO EXISTING MAIN TO MINIMIZE NUMBER OF MECHANICAL JOINTS.



Town of **MEDWAY**  
DEPARTMENT OF PUBLIC SERVICES

**GATE VALVE**

DATE:  
JULY 2016  
REV:  
0

DETAIL NO.  
**W-06**

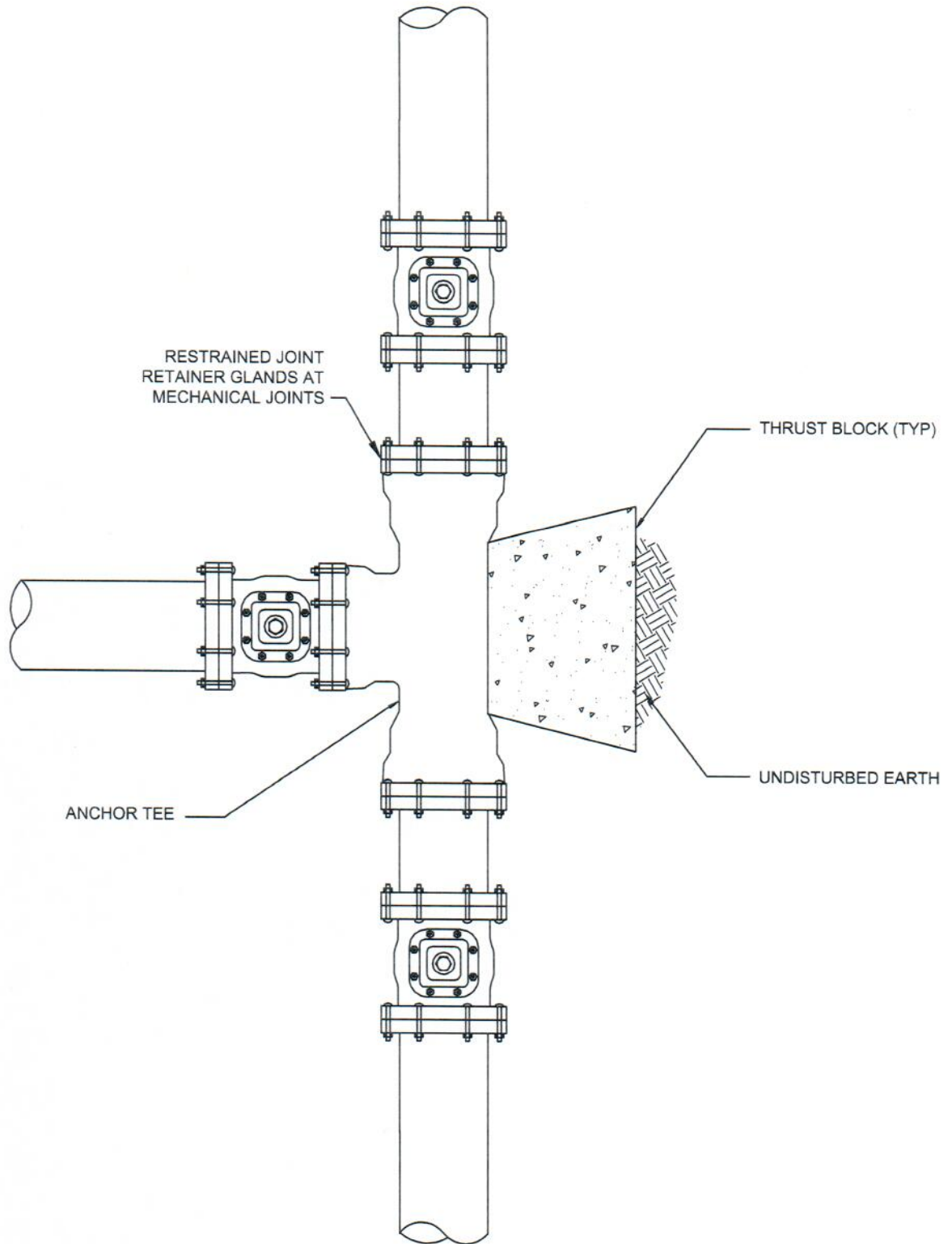

NOT TO SCALE



Town of **MEDWAY**  
DEPARTMENT OF PUBLIC SERVICES

TYPICAL ANCHOR TEE  
INSTALLATION

DATE:  
JULY 2016  
REV:  
0

DETAIL NO.  
**W-06**

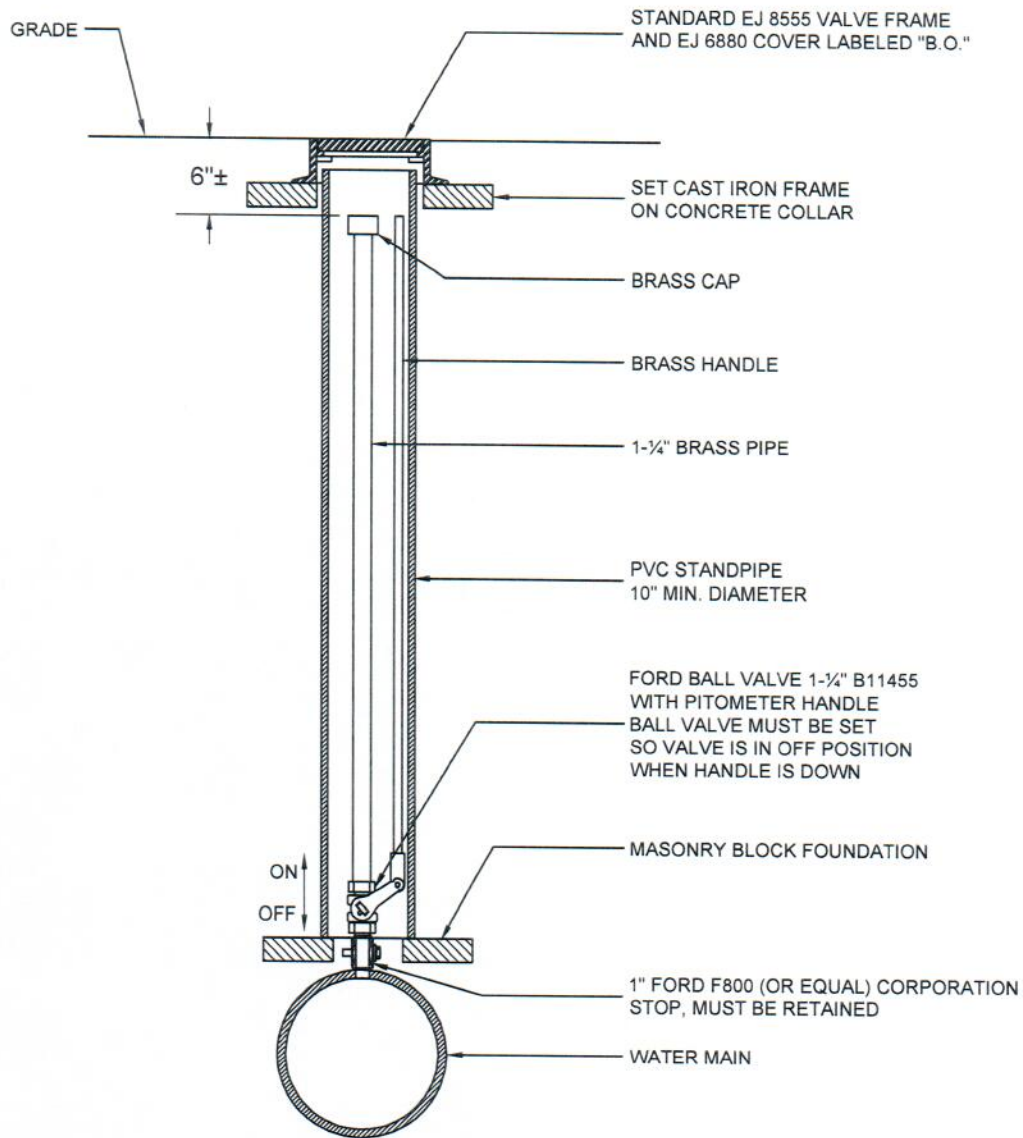

NOT TO SCALE



Town of **MEDWAY**  
DEPARTMENT OF PUBLIC SERVICES

**AIR RELEASE VALVE/BLOW-OFF**

DATE:  
APRIL 2021  
REV:  
0

DETAIL NO.  
**W-07**

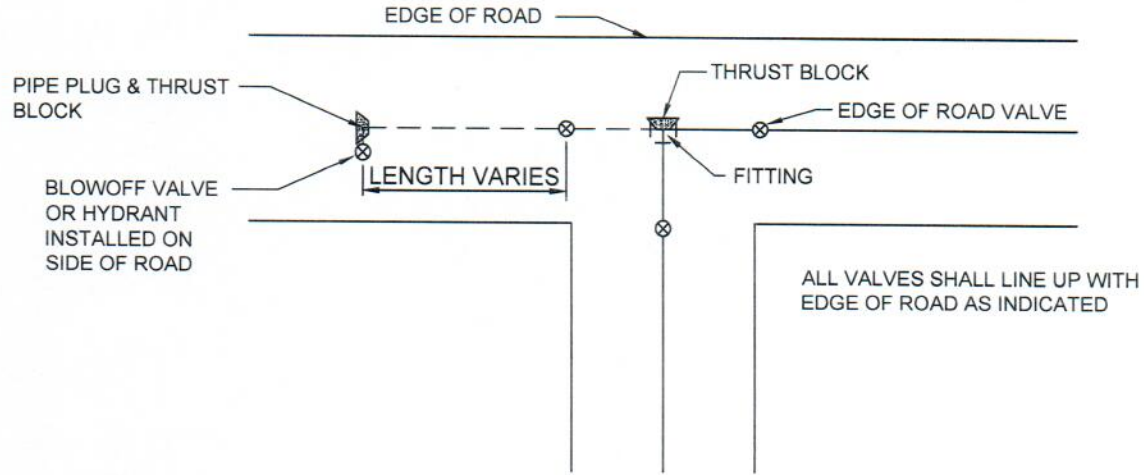
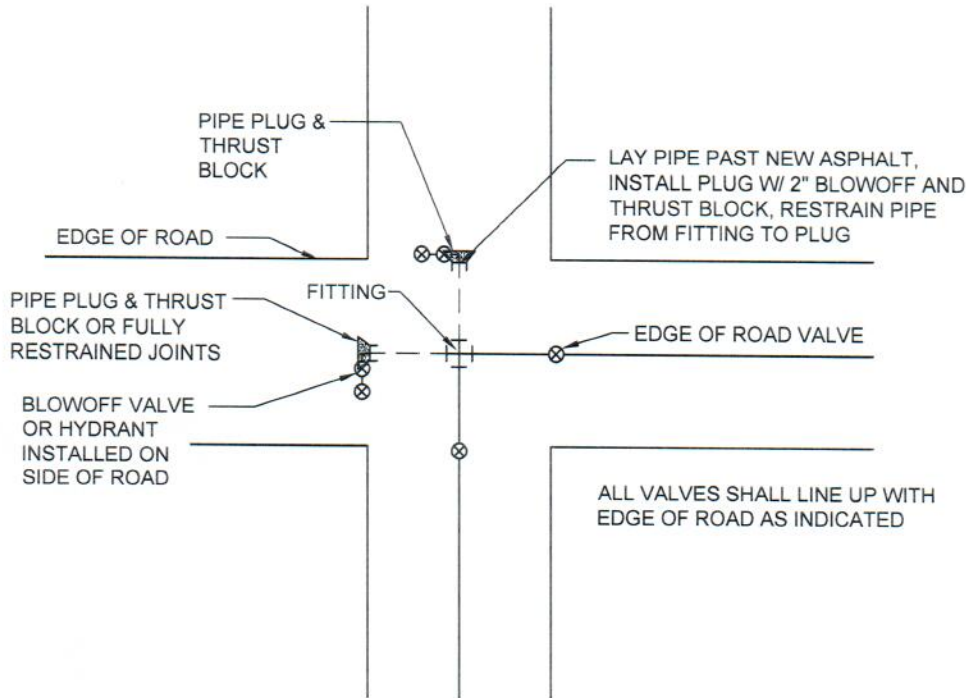

NOT TO SCALE



Town of **MEDWAY**  
DEPARTMENT OF PUBLIC SERVICES

**VALVE LOCATION  
AT INTERSECTION**

DATE:  
APRIL 2021  
REV:  
0

DETAIL NO.  
**W-08**

NOTE: COVER RAISED  
DIAMOND DESIGN

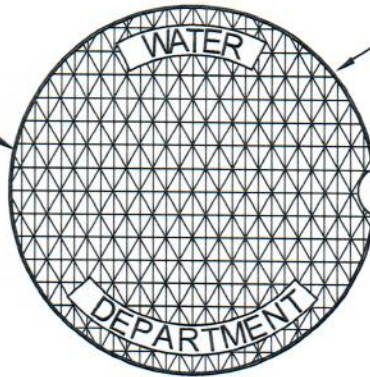

NOTE: COVER READS:  
"WATER"  
"DEPARTMENT"  
IN 3/4" LETTERS

NOT TO SCALE



Town of **MEDWAY**  
DEPARTMENT OF PUBLIC SERVICES

WATER GATE COVER

DATE:  
JULY 2016

REV:  
0

DETAIL NO.  
**W-09**

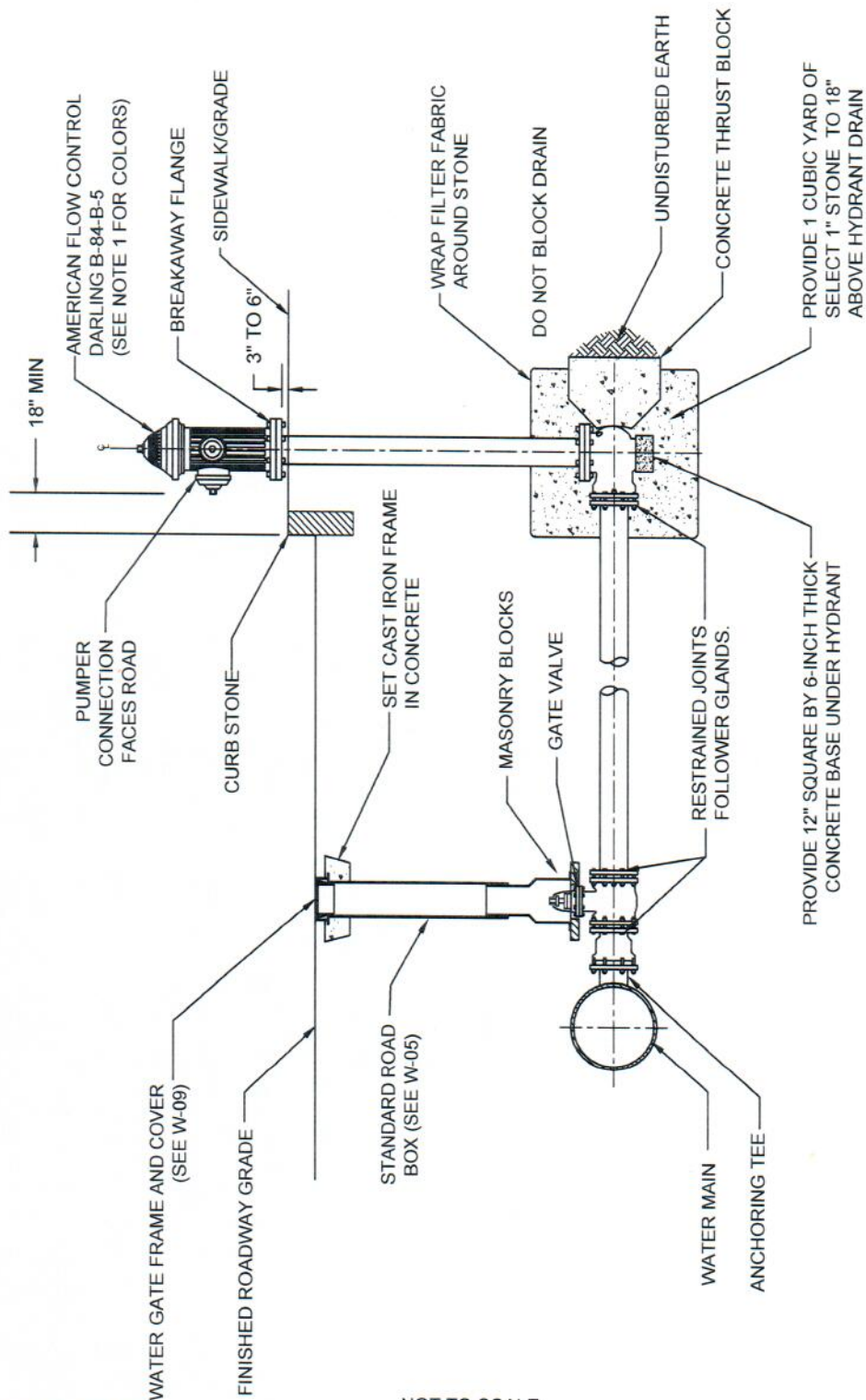

18" MIN

DO NOT BLOCK DRAIN

UNDISTURBED EARTH

CONCRETE THRUST BLOCK

PROVIDE 1 CUBIC YARD OF SELECT 1" STONE TO 18" ABOVE HYDRANT DRAIN

PROVIDE 12" SQUARE BY 6-INCH THICK CONCRETE BASE UNDER HYDRANT

NOT TO SCALE

**NOTES:**

1. HYDRANT SHALL BE PAINTED THE FOLLOWING COLORS:  
 BARREL: BLUE SAFETY (COLOR CODE: 822913)  
 COVER & CAPS: SILVER (COLOR CODE: 822903)
2. HYDRANT SHALL OPEN LEFT PER TOWN STANDARDS.
3. HYDRANT LATERAL SHALL BE FULLY RESTRAINED.
4. 3'-0" CLEAR AND FLAT ALL AROUND HYDRANT PER NFPA STANDARD.

NOT TO SCALE



Town of **MEDWAY**  
 DEPARTMENT OF PUBLIC SERVICES

**FIRE HYDRANT INSTALLATION**

DATE:  
 APRIL 2021  
 REV:  
 0

DETAIL NO.  
**W-10**

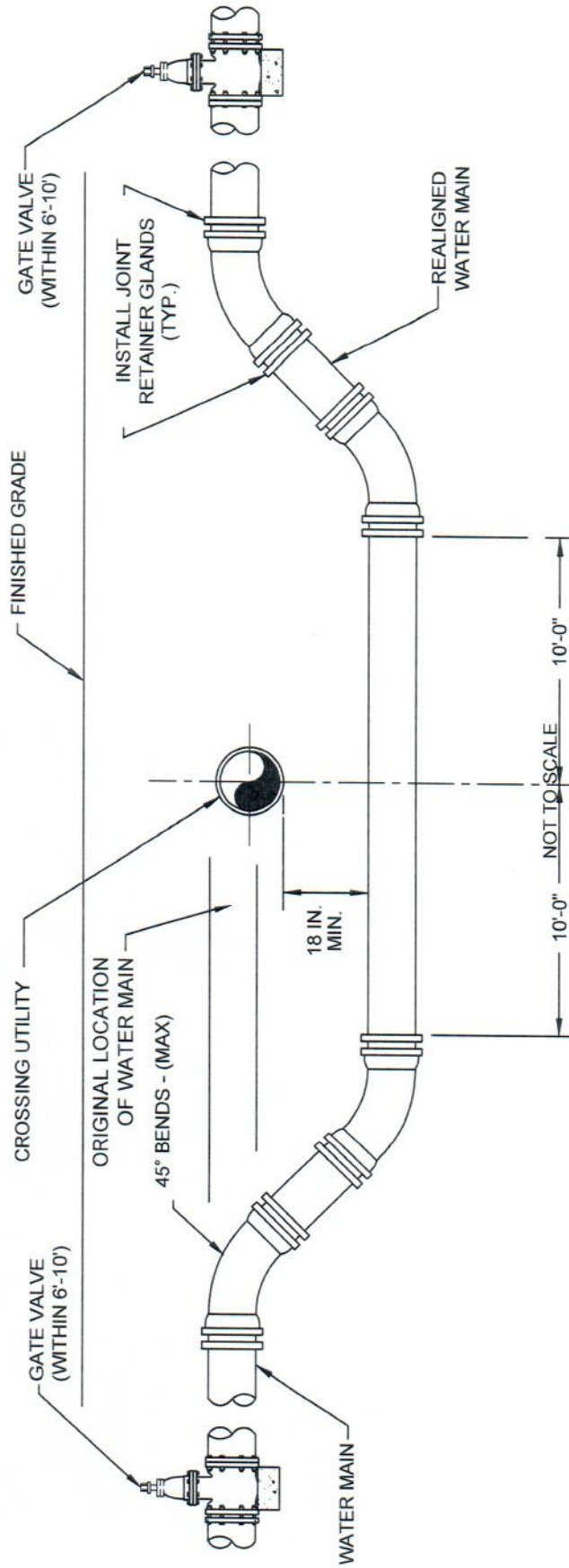

NOTES:

1. ALL FITTINGS AND JOINTS IN LOWERING AREA TO BE RESTRAINED. TOWN MAY REQUIRE THREADED ROD RESTRAINTS IN CERTAIN SITUATIONS.
2. WHEN IT IS IMPOSSIBLE TO OBTAIN HORIZONTAL OR VERTICAL SEPARATION AS INDICATED IN THE DETAIL ABOVE, BOTH THE WATER AND THE SEWER SHOULD BE ENCASED IN CONTROL DENSITY FILL FOR A DISTANCE OF 10 FEET ON EITHER SIDE OF THE CROSSING.
3. ALL DUCTILE IRON PIPE AND FITTINGS SHALL BE WRAPPED WITH POLYETHYLENE ENCASEMENT WHEN CONTACTING CONTROL DENSITY FILL.



Town of **MEDWAY**  
DEPARTMENT OF PUBLIC SERVICES

**WATER MAIN LOWERING DETAIL**

DATE:  
APRIL 2021  
REV:  
0

DETAIL NO.  
**W-11**

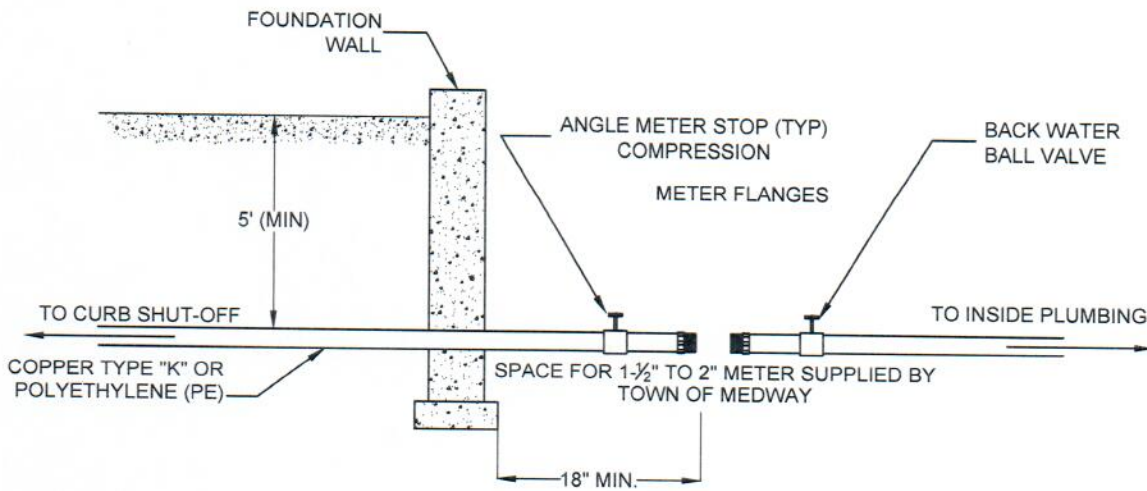
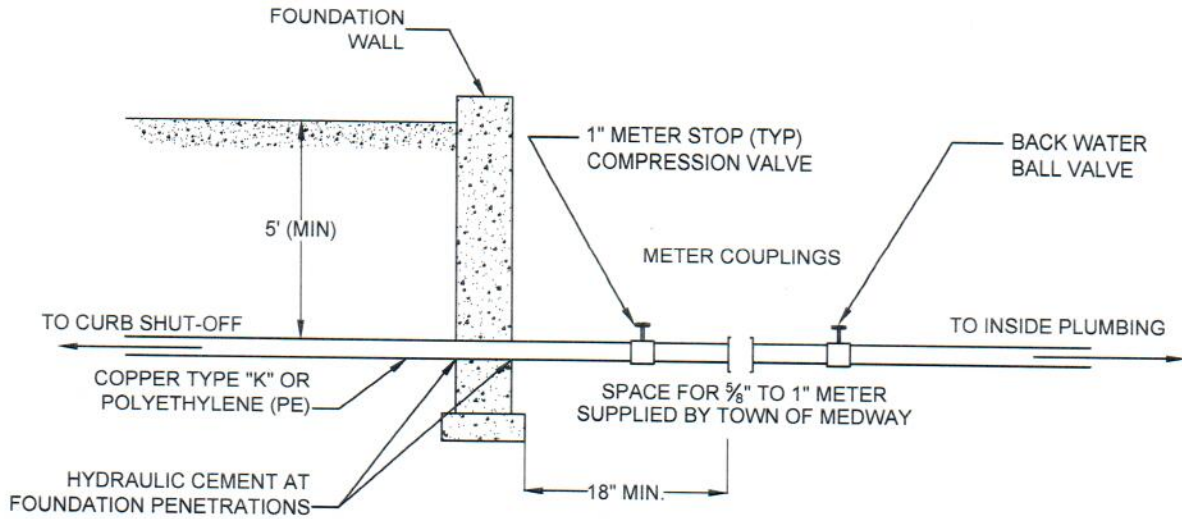

NOT TO SCALE

**NOTES:**

1. METERS SHALL BE INSTALLED HORIZONTAL.
2. BACKFLOW PREVENTION SHALL BE PLACED IN INTERIOR OF HOME/BUSINESS TO PREVENT CONTAMINATION OF TOWN WATER SUPPLY IN THE EVENT OF CROSS CONNECTIONS.
3. HOME/BUSINESS OWNER SHALL TAKE ALL NECESSARY PRECAUTIONS TO PREVENT CROSS CONNECTIONS BETWEEN POTABLE/NON-POTABLE WATER SUPPLIES.
4. FOR PRESSURE ABOVE 80 PSI MEASURED AT THE METER, CUSTOMER SHALL INSTALL A PRESSURE REDUCING VALVE AFTER THE WATER METER.



Town of **MEDWAY**  
DEPARTMENT OF PUBLIC SERVICES

**METER INSTALLATION**

DATE:  
APRIL 2021  
REV:  
0

DETAIL NO.  
**W-12**

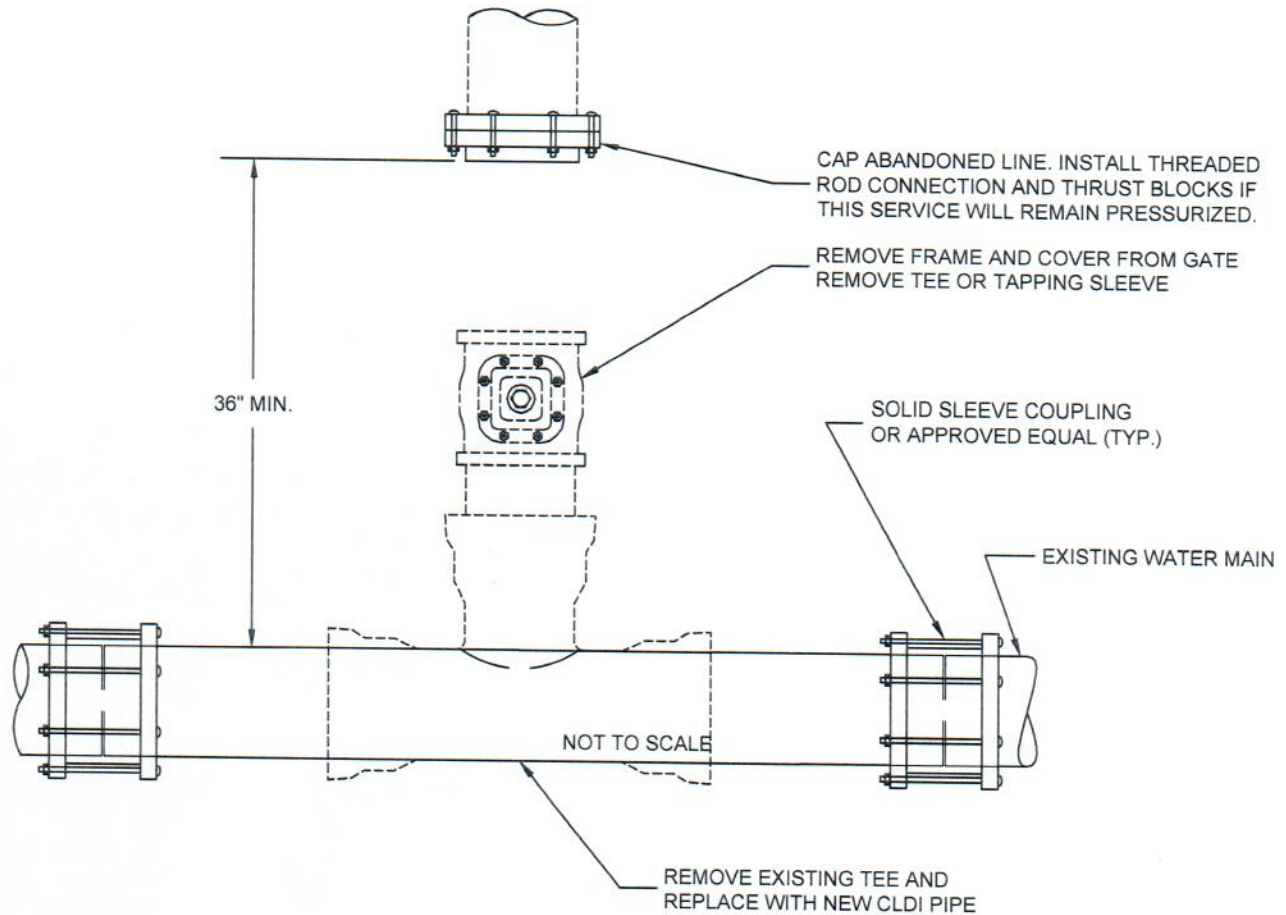

**NOTES:**

1. ALL WORK MUST BE PERFORMED BY A MEDWAY APPROVED LICENSED AND BONDED CONTRACTOR.
2. THIS PROCEDURE WILL INVOLVE A MAIN LINE SHUT DOWN. THE CONTRACTOR SHALL COORDINATE WITH MEDWAY'S D.P.S. WATER OPERATIONS DIVISION.
3. WRITTEN NOTIFICATION OF ALL AFFECTED CUSTOMERS MUST BE PERFORMED BY THE CONTRACTOR 48 HOURS PRIOR TO THE WORK.
4. ALL WORK MUST BE PERMITTED BY MEDWAY AND ALL OTHER APPROPRIATE AGENCIES.
5. ALL WORK MUST BE INSPECTED BY MEDWAY INSPECTOR OR DESIGNEE PRIOR TO BACKFILLING.



Town of **MEDWAY**  
DEPARTMENT OF PUBLIC SERVICES

**DETAIL OF CUT AND REMOVE OF  
WATER CONNECTION 4" AND OVER**

DATE:  
APRIL 2021  
REV:  
0

DETAIL NO.  
**W-13**

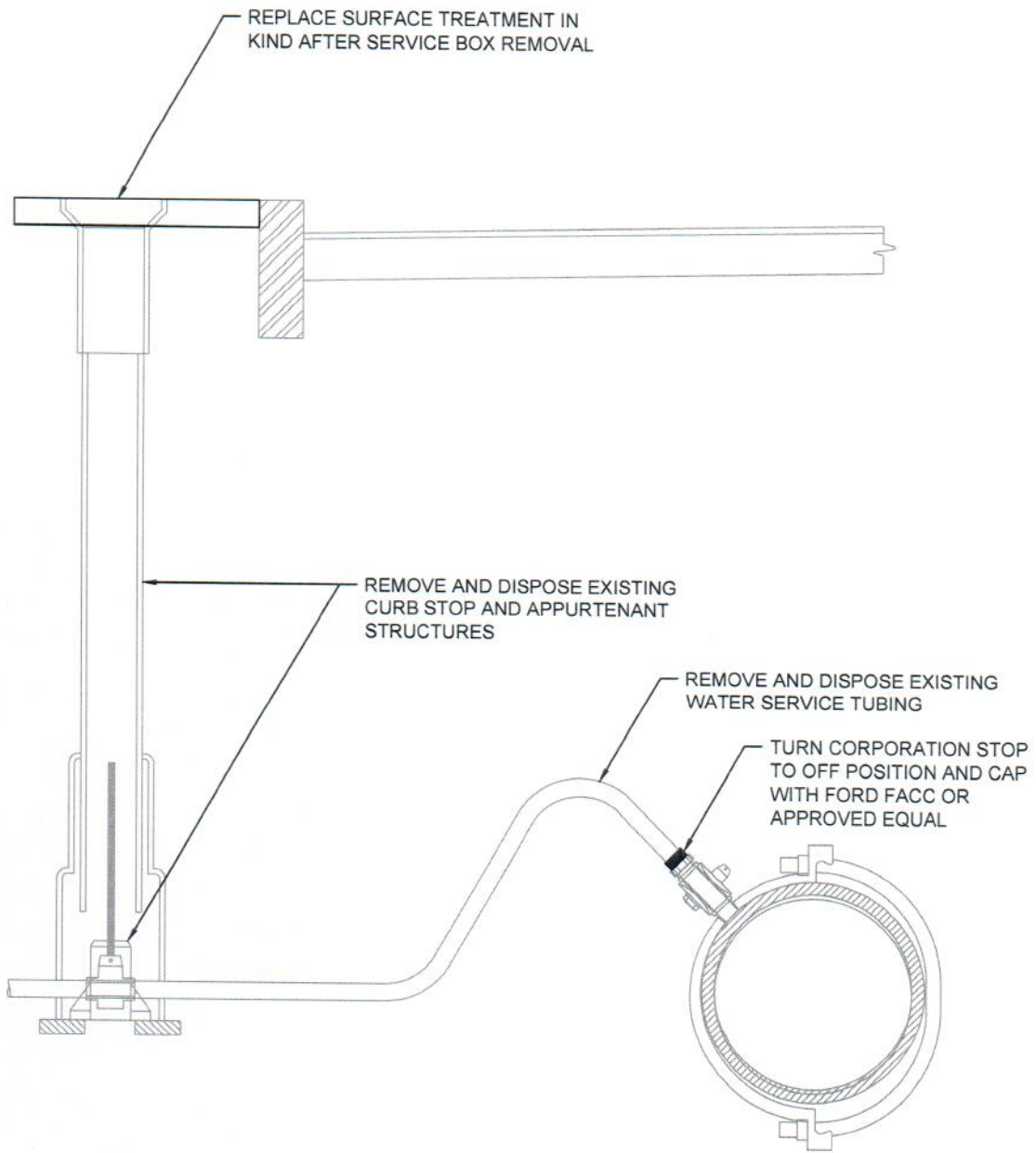

NOT TO SCALE

**NOTES:**

1. SERVICE DEMOLITIONS SHALL BE INSPECTED BY MEDWAY DPS OFFICIALS.

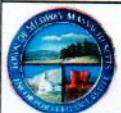

Town of **MEDWAY**  
DEPARTMENT OF PUBLIC SERVICES

**WATER SERVICE DISCONNECTION**

DATE:  
APRIL 2021  
REV:  
0

DETAIL NO.  
**W-14**

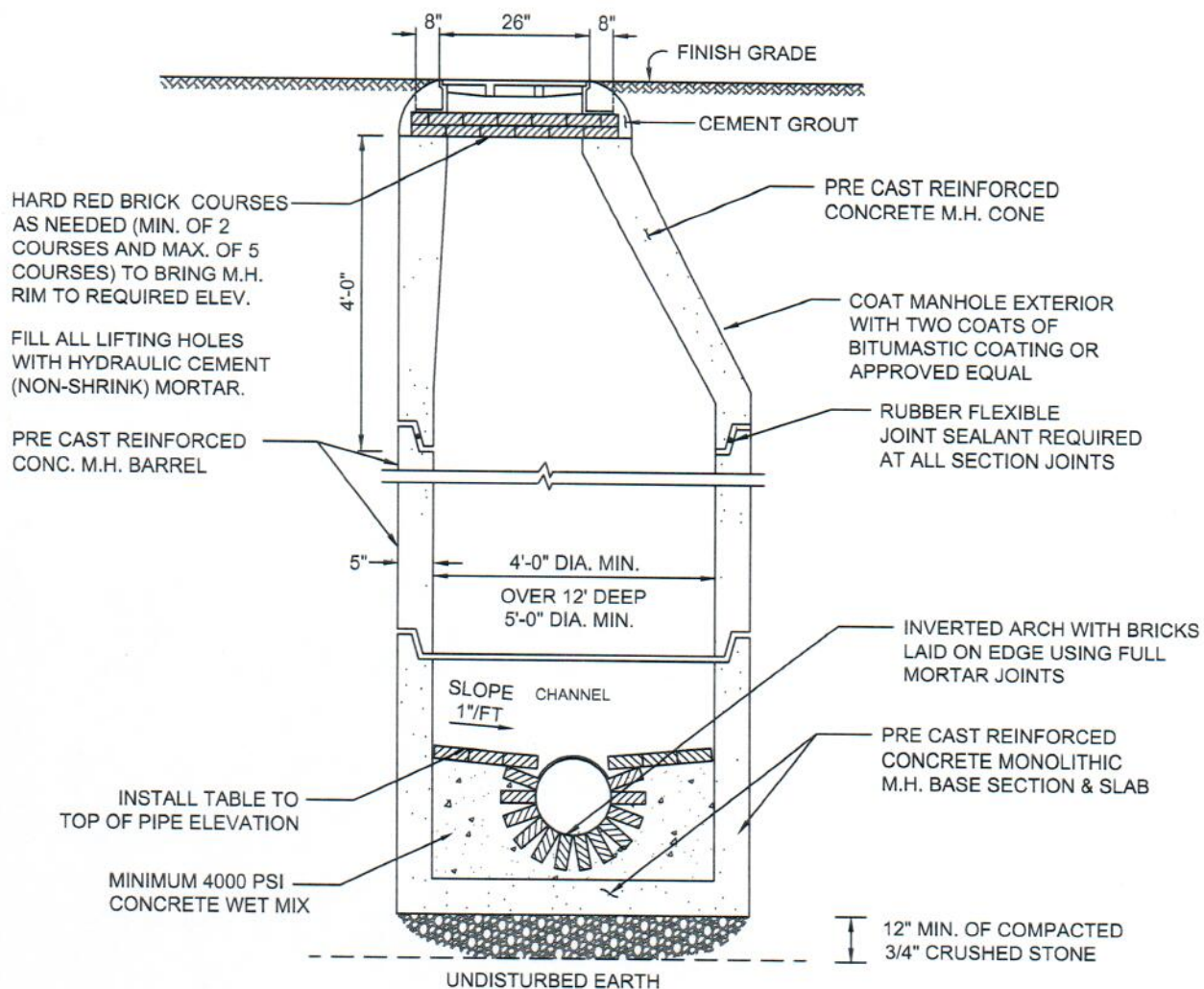

NOT TO SCALE

**NOTES:**

1. TYPICAL SANITARY MANHOLE TO BE 4 FEET IN DIAMETER.
2. 5'-0" DIAMETER FOR ALL MANHOLE DEPTHS GREATER THAN 12 FEET OR WHEN ORDERED BY THE ENGINEER.
3. 6" MIN. WALL THICKNESS AND 7" MIN. BASE THICKNESS WITH 5'-0" DIAMETER MANHOLES.
4. INNER EDGE OF BRICK TABLE TO BE AT ELEVATION OF CROWN OF TOP OF PIPE.
5. DESIGN LOAD - HS20.
6. ALL INVERTS SHALL BE 4,000 PSI CEMENT CONCRETE IN VOID AREAS AND RED SEWER BRICK CONSTRUCTION.
7. INVERTS SHALL NOT BE BUILT ABOVE GRADE. ALL INVERTS SHALL BE BUILT IN PLACE WITH ALL PIPES INSTALLED.



Town of **MEDWAY**  
DEPARTMENT OF PUBLIC SERVICES

**TYPICAL SEWER MANHOLE**

DATE:  
JULY 2016  
REV:  
0

DETAIL NO.  
**S-01**

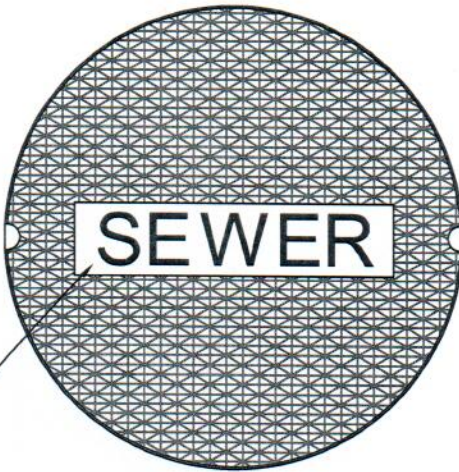

COVER SHALL READ  
"SEWER" IN 2" LETTERING

NOT TO SCALE

**NOTES:**

1. COVER LETTERING DETAIL APPLIES TO ALL COVER SIZES AND WATERTIGHT MANHOLE COVERS IN ACCORDANCE WITH NOTES IN TYPICAL MANHOLE DETAIL.
2. ALL COVERS MUST BE MIN. 26 INCH WIDE. COVERS MUST BE AS SPECIFIED BY EJCO ITEM 2111A COVER OR APPROVED EQUAL.
3. ALL FRAMES MUST BE MIN. 6 INCH HIGH. FRAMES MUST BE AS SPECIFIED BY EJCO ITEM 2111Z FRAME OR APPROVED EQUAL.



Town of **MEDWAY**  
DEPARTMENT OF PUBLIC SERVICES

**SEWER MANHOLE COVER**

DATE:  
JULY 2016

REV:  
0

DETAIL NO.  
**S-02**

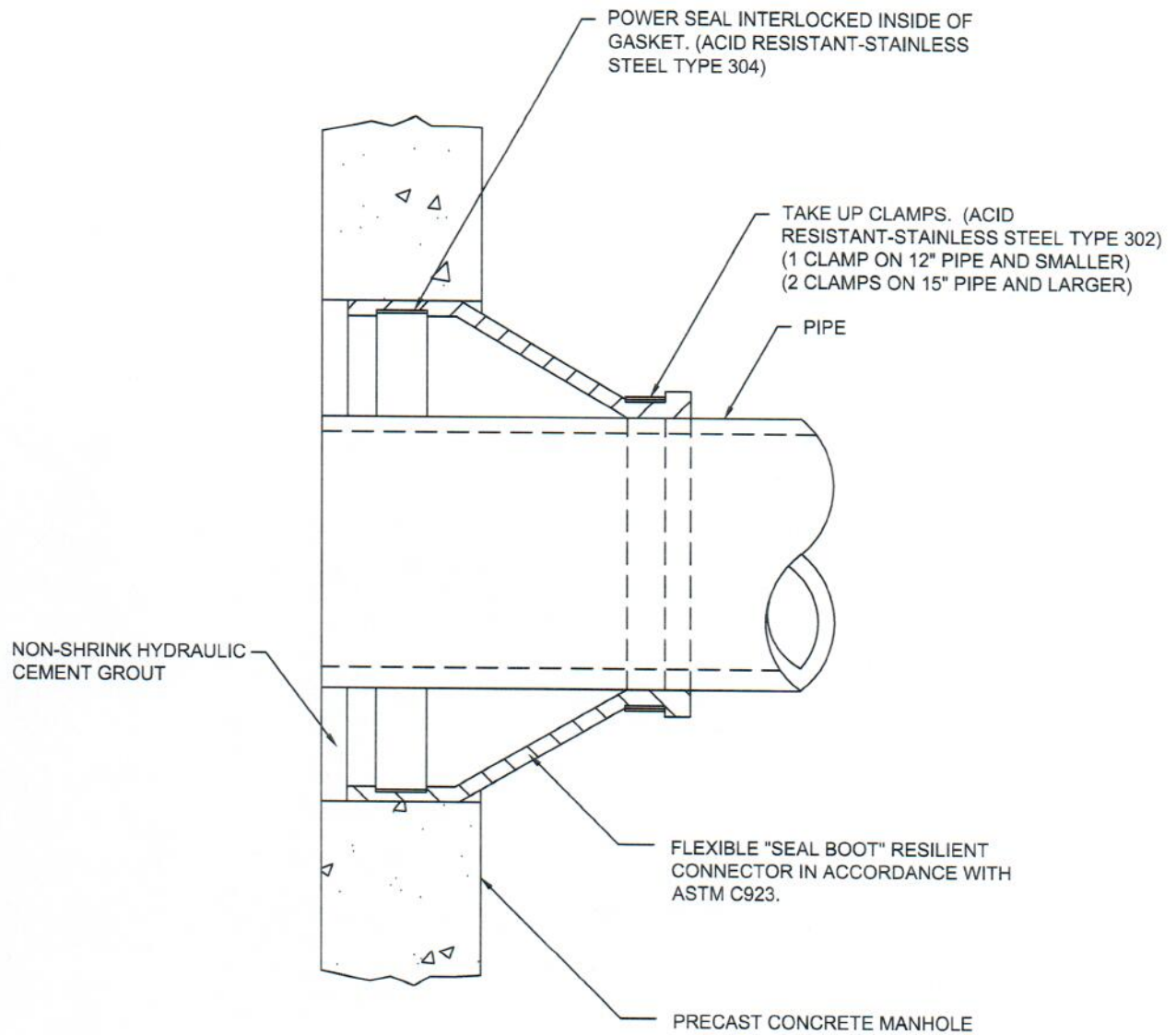

NOT TO SCALE



Town of **MEDWAY**  
 DEPARTMENT OF PUBLIC SERVICES

**MANHOLE SEAL (TYPICAL)**

DATE:  
 JULY 2016  
 REV:  
 0

DETAIL NO.  
**S-03**

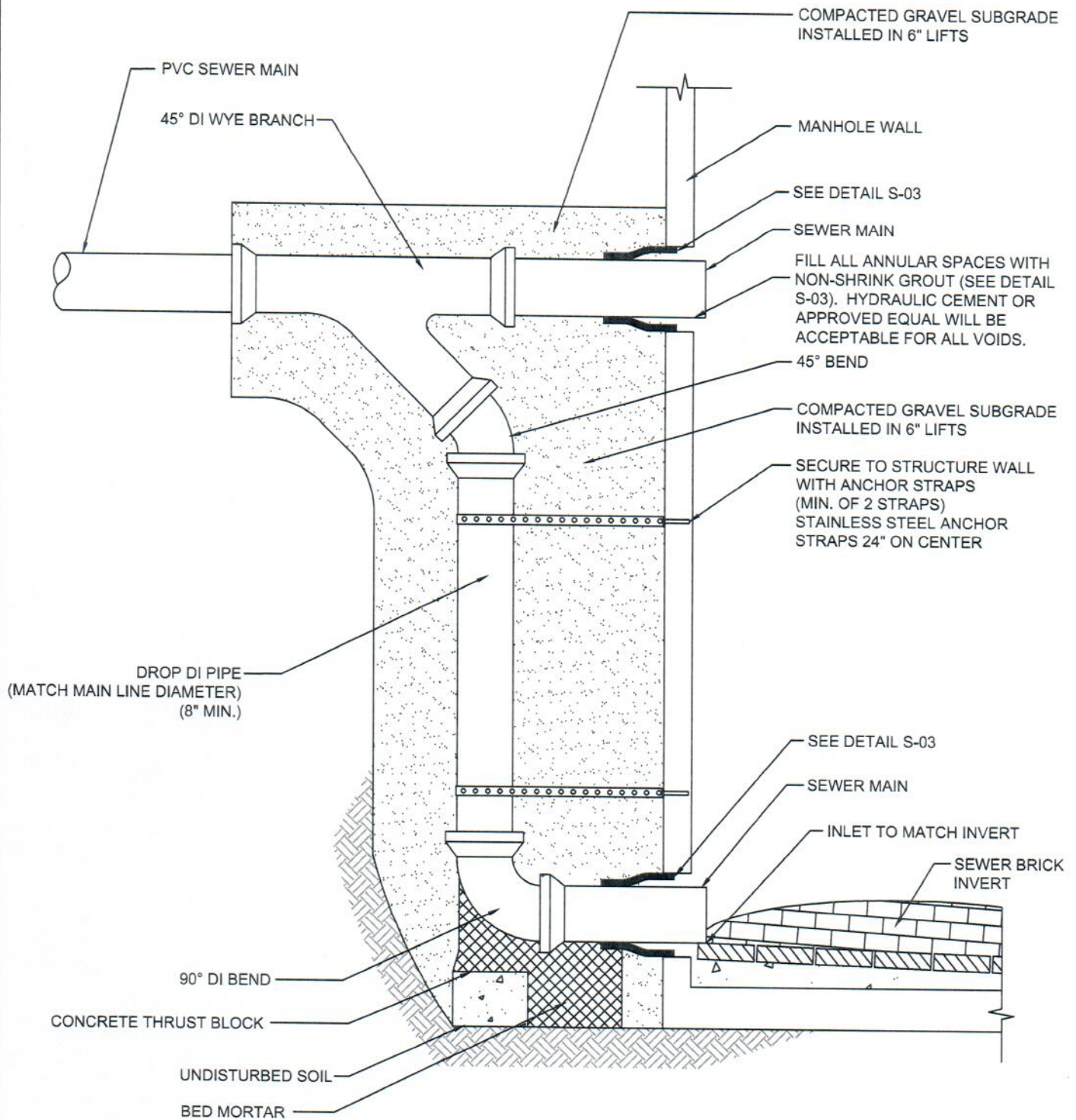

NOT TO SCALE

**NOTES:**

1. BOTH PVC PIPE OR DUCTILE IRON PIPE ARE ACCEPTABLE.
2. IF DUCTILE IRON PIPE IS USED, 90° BENDS SHALL BE POLY-WRAPPED WITHIN THE LIMITS OF THE MORTARED SECTION.
3. ALL ALTERNATIVES TO MANHOLE CONNECTIONS SHOULD BE EXHAUSTED. MANHOLE CONNECTIONS ALLOWED ONLY BY TOWN APPROVAL. WYE CONNECTIONS TO SEWER MAIN PREFERRED FOR SERVICE CONNECTIONS.



Town of **MEDWAY**  
DEPARTMENT OF PUBLIC SERVICES

**TYPICAL DROP MANHOLE  
(OUTSIDE)**

DATE:  
JULY 2016  
REV:  
0

DETAIL NO.  
**S-04**

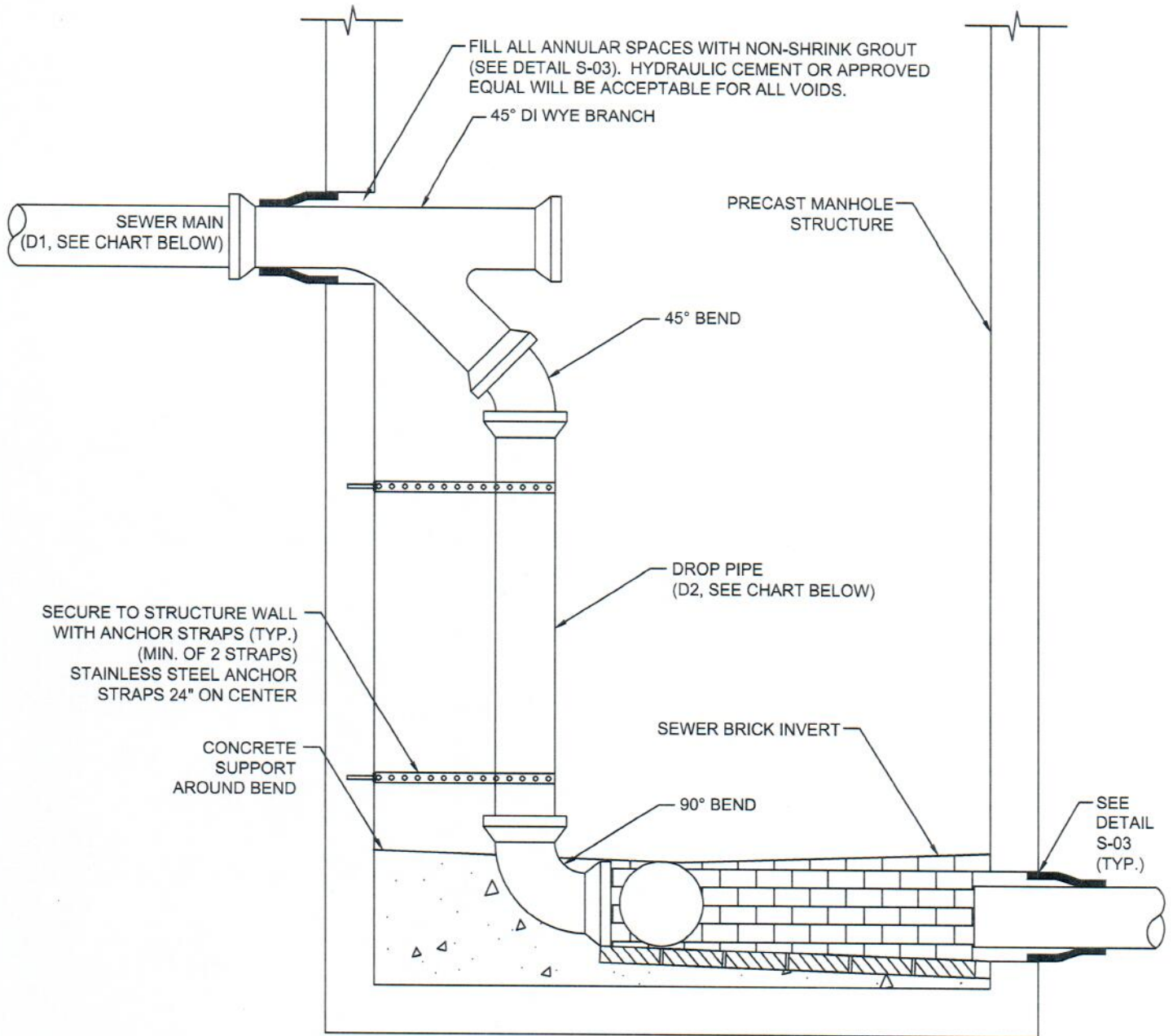

PIPE SIZES

INLET SEWER D1	DROP SEWER D2
15"	12"
12"	10"
8"	8"

**NOTES:**

NOT TO SCALE

- BOTH PVC AND DUCTILE IRON PIPE ARE ACCEPTABLE. IF DUCTILE IRON PIPE IS USED, 90 BENDS SHALL BE POLY-WRAPPED WITHIN THE LIMITS OF THE MORTARED SECTION.
- DROP MANHOLE INSIDE DIAMETER TO BE 5' FOR SEWER PIPES LESS THAN 12" IN DIAMETER. A 6' DIAMETER MANHOLE SHALL BE USED FOR PIPE SIZES 12" AND GREATER.
- DIMENSIONS AND CONSTRUCTION OF DROP MANHOLE TO BE SIMILAR TO TYPICAL SEWER MANHOLE INSTALLATION EXCEPT FOR PIPE ALIGNMENT AS SHOWN.
- ALL ALTERNATIVES TO MANHOLE CONNECTIONS SHOULD BE EXHAUSTED. MANHOLE CONNECTIONS ALLOWED ONLY BY TOWN APPROVAL. WYE CONNECTIONS TO SEWER MAIN PREFERRED FOR SERVICE CONNECTIONS.



Town of **MEDWAY**  
DEPARTMENT OF PUBLIC SERVICES

**TYPICAL DROP MANHOLE  
(INSIDE)**

DATE:  
JULY 2016  
REV:  
0

DETAIL NO.  
**S-05**

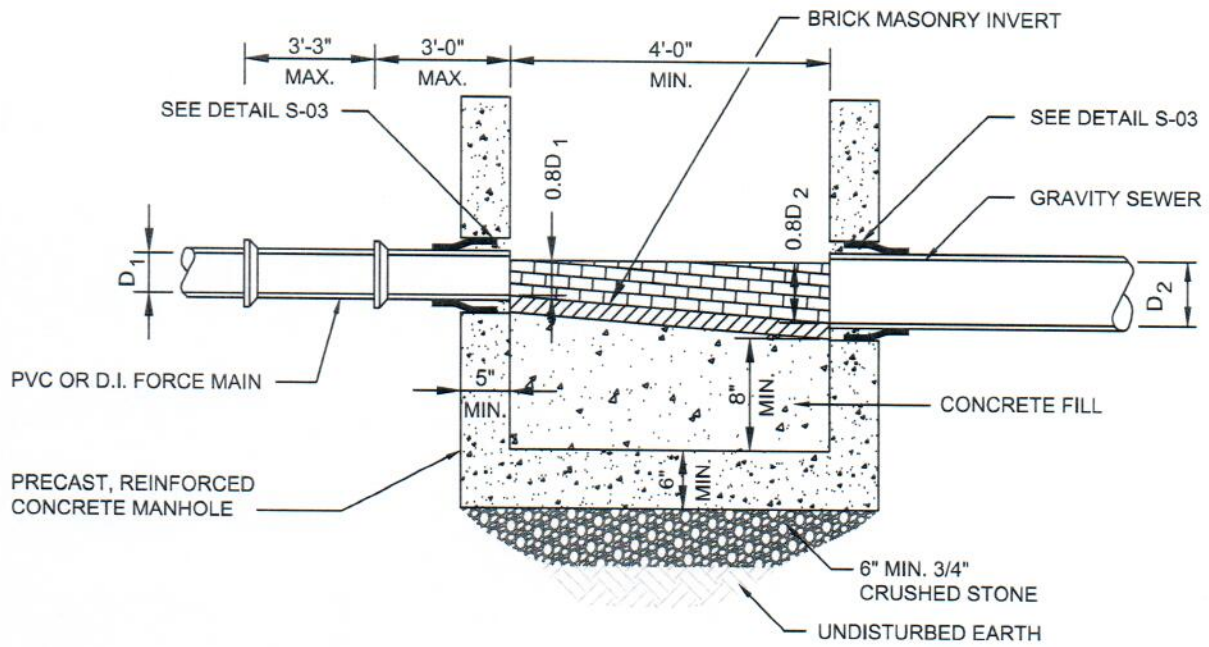

NOT TO SCALE

**NOTES:**

- GRAVITY MANHOLE SHALL BE PLACED ON PRIVATE PROPERTY.



Town of **MEDWAY**  
DEPARTMENT OF PUBLIC SERVICES

**FORCEMAIN MANHOLE**

DATE:  
JULY 2016  
REV:  
0

DETAIL NO.  
**S-06**

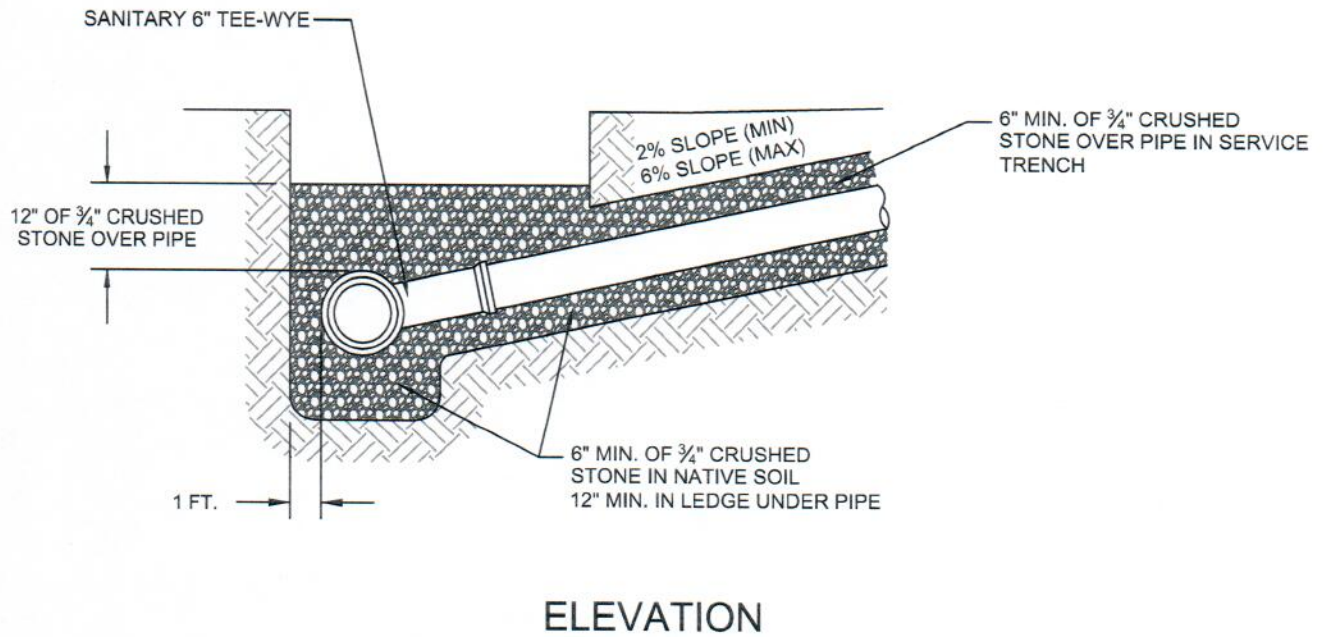
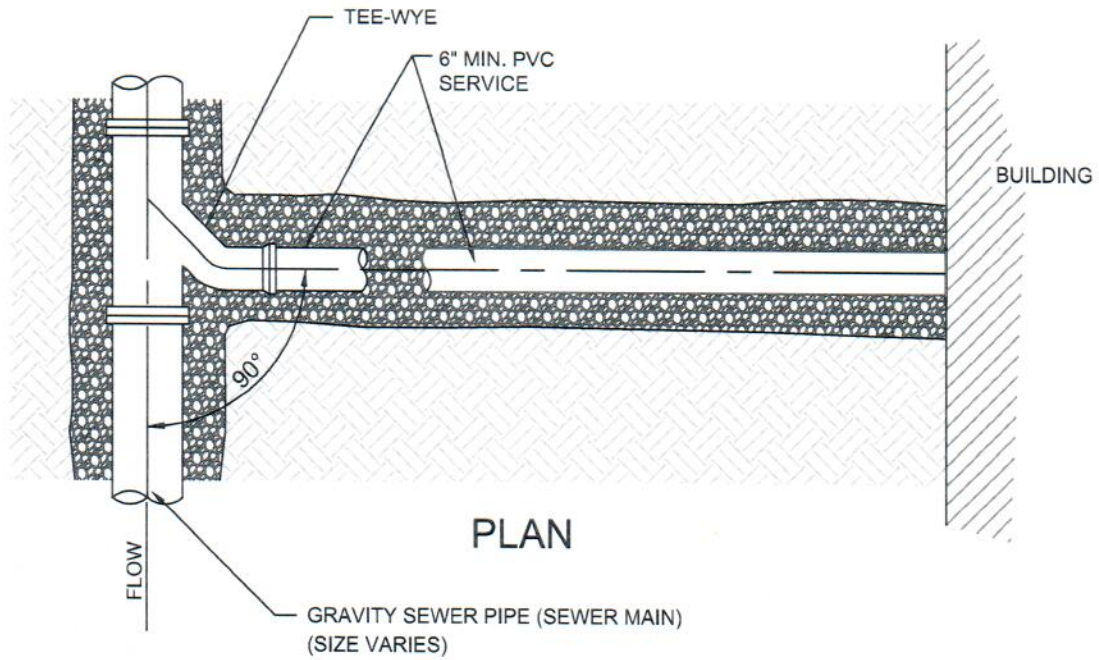

NOT TO SCALE



Town of **MEDWAY**  
DEPARTMENT OF PUBLIC SERVICES

**SERVICE CONNECTION  
(GRAVITY)**

DATE:  
JULY 2016  
REV:  
0

DETAIL NO.  
**S-07**

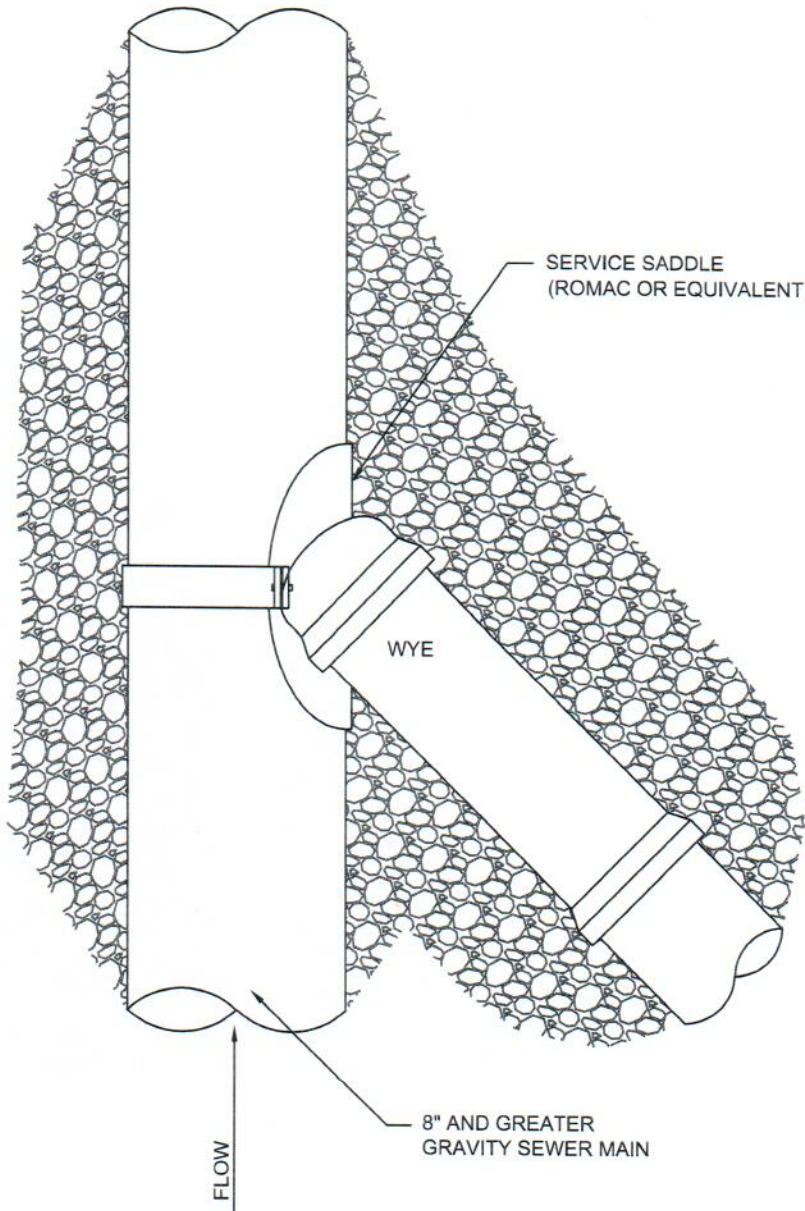

NOT TO SCALE

**NOTES:**

1. INSTALL SADDLE FIRST, THEN CORE HOLE.
2. INSERT A-TEE SERVICE CONNECTORS MAY BE ALLOWED UPON SPECIFIC D.P.S. APPROVAL.



Town of **MEDWAY**  
DEPARTMENT OF PUBLIC SERVICES

**SERVICE CONNECTION  
(SADDLE)**

DATE:  
JULY 2016

REV:  
0

DETAIL NO.  
**S-08**

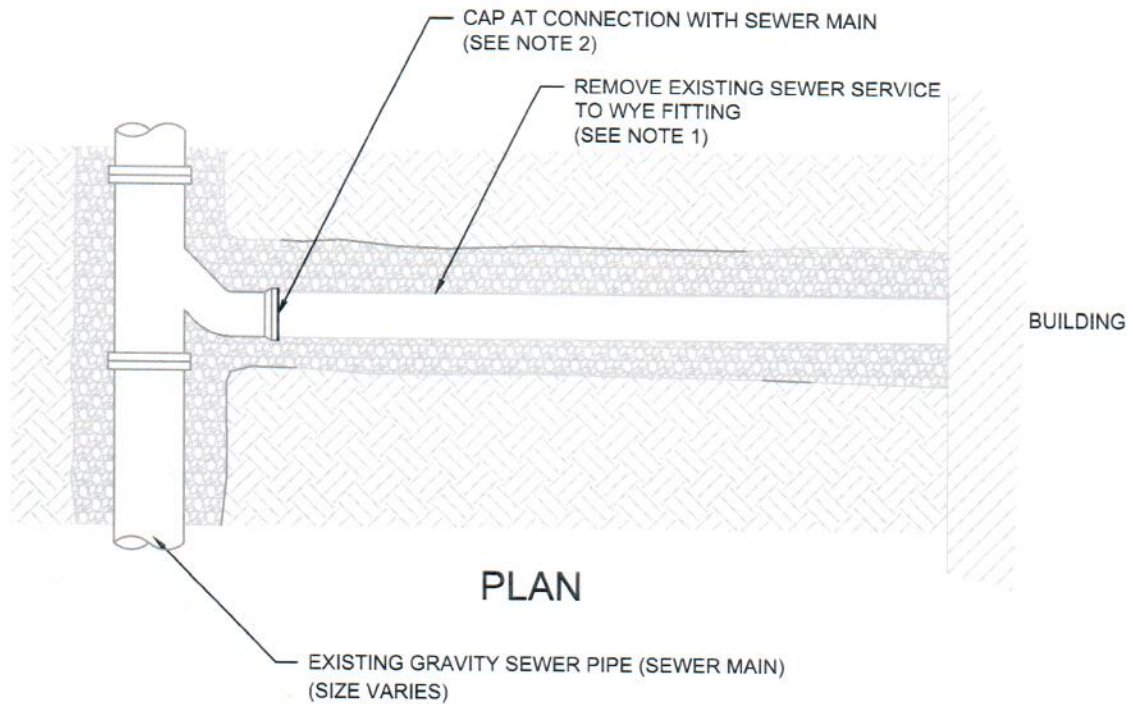

NOT TO SCALE

**NOTES:**

1. TRENCHES WITHIN RIGHT OF WAY SHALL BE BACKFILLED WITH CONTROLLED DENSITY FILL.
2. CAP TYPE SHALL BE DETERMINED ON A CASE BY CASE BASIS AND REVIEWED BY THE TOWN PRIOR TO INSTALLATION.



Town of **MEDWAY**  
DEPARTMENT OF PUBLIC SERVICES

**SERVICE DISCONNECTION**

DATE:  
JULY 2016

REV:  
0

DETAIL NO.  
**S-09**

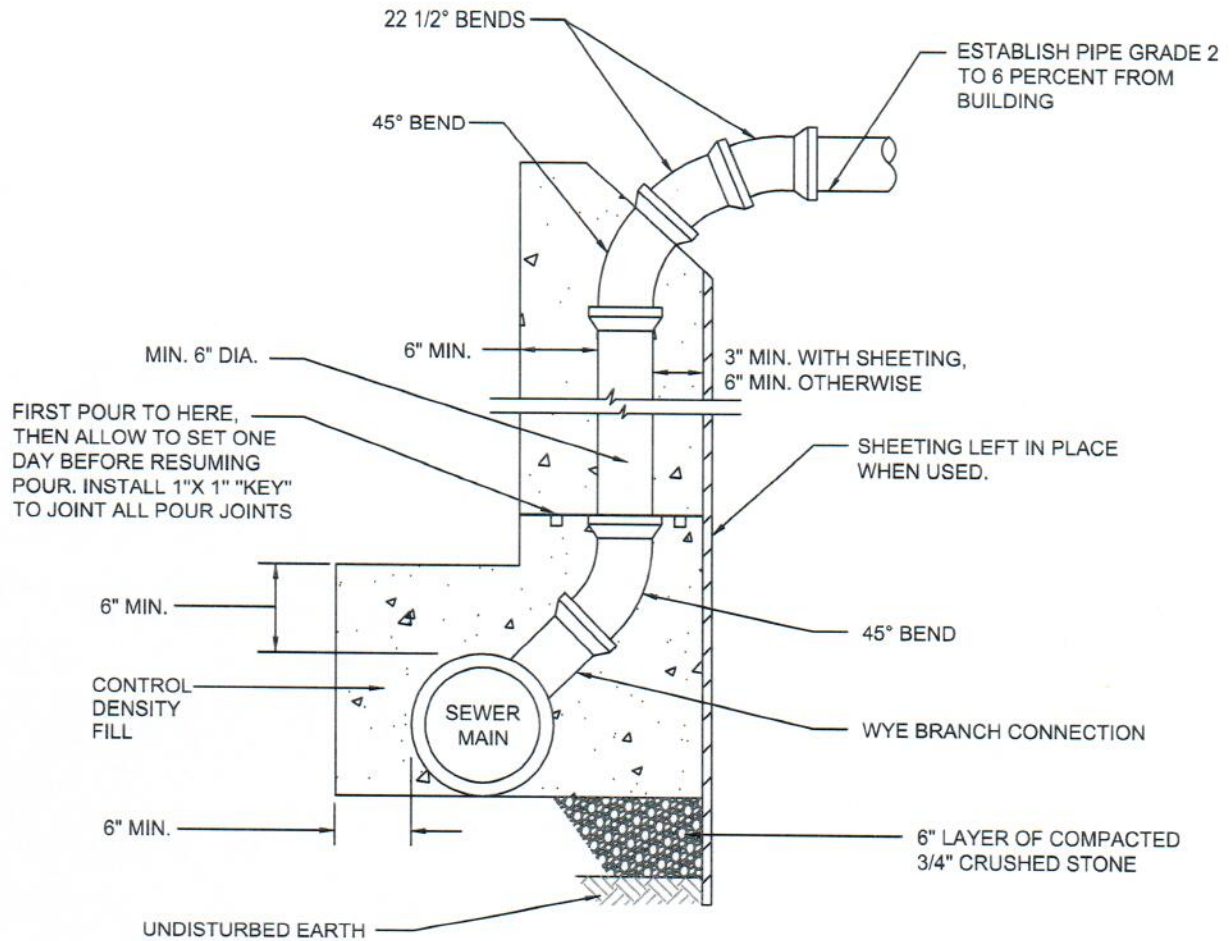

NOT TO SCALE

NOTES:

1. INSERT A-TEE SERVICE CONNECTORS MAY BE ALLOWED UPON SPECIFIC D.P.S. APPROVAL.



Town of **MEDWAY**  
DEPARTMENT OF PUBLIC SERVICES

CHIMNEY

DATE:  
JULY 2016  
REV:  
0

DETAIL NO.  
**S-10**

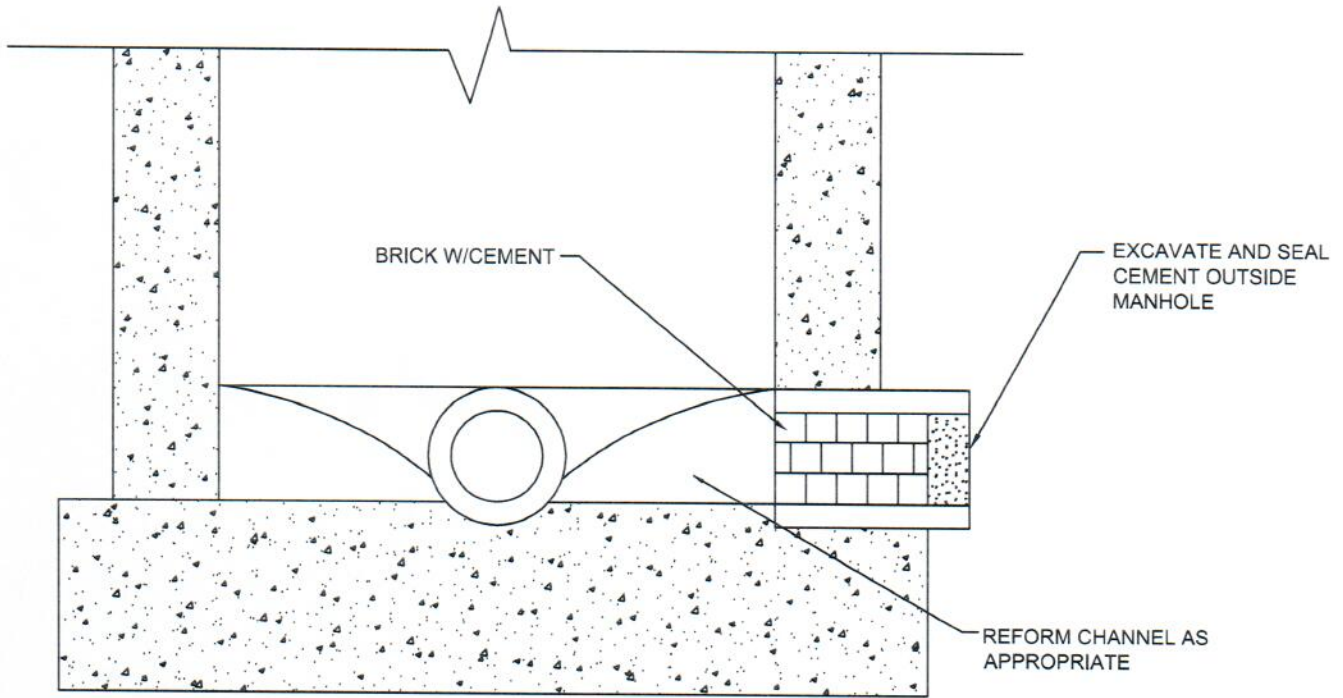

NOT TO SCALE

**NOTES:**

1. THIS DRAWING DEPICTS NON-PLASTIC PIPE.
2. USE MECHANICAL PLUGS WHEN ABANDONING PLASTIC PIPES.



Town of **MEDWAY**  
DEPARTMENT OF PUBLIC SERVICES

**PLUG FOR ABANDONING  
SANITARY SEWER**

DATE:  
JULY 2016  
REV:  
0

DETAIL NO.  
**S-11**

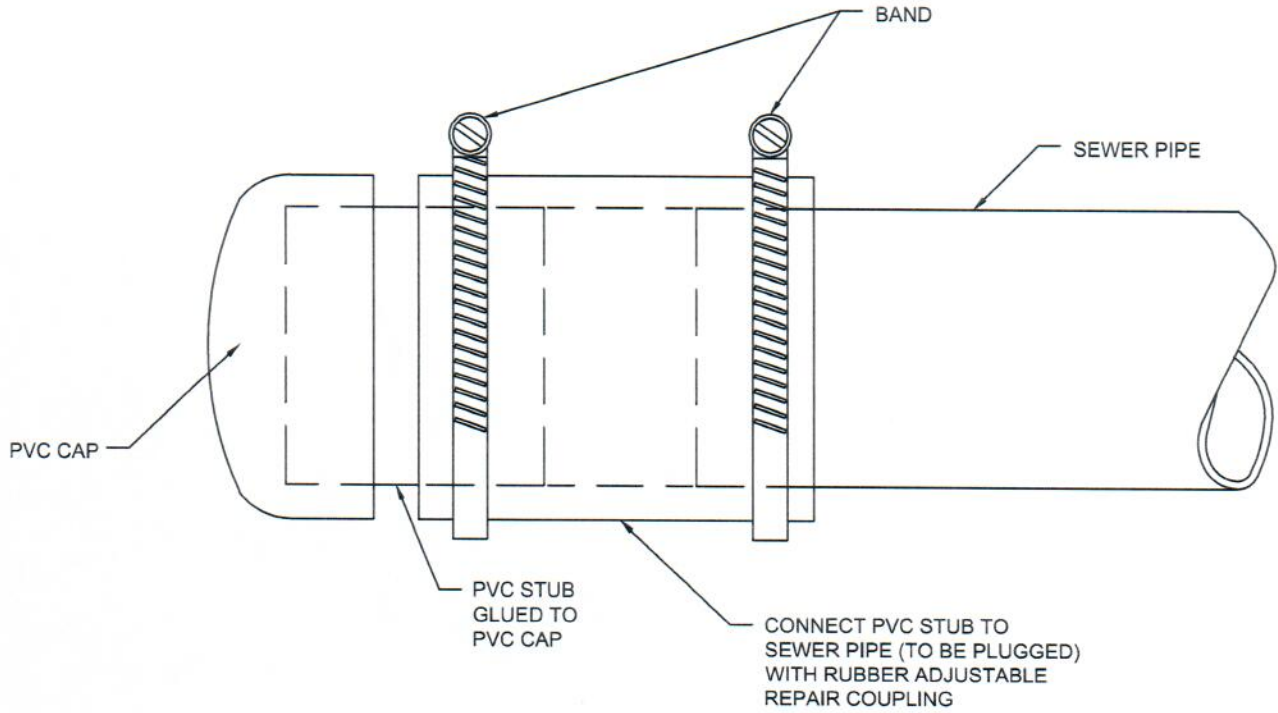

NOT TO SCALE



Town of **MEDWAY**  
DEPARTMENT OF PUBLIC SERVICES

**PLUG FOR SANITARY SEWER**

DATE:  
JULY 2016  
REV:  
0

DETAIL NO.  
**S-12**

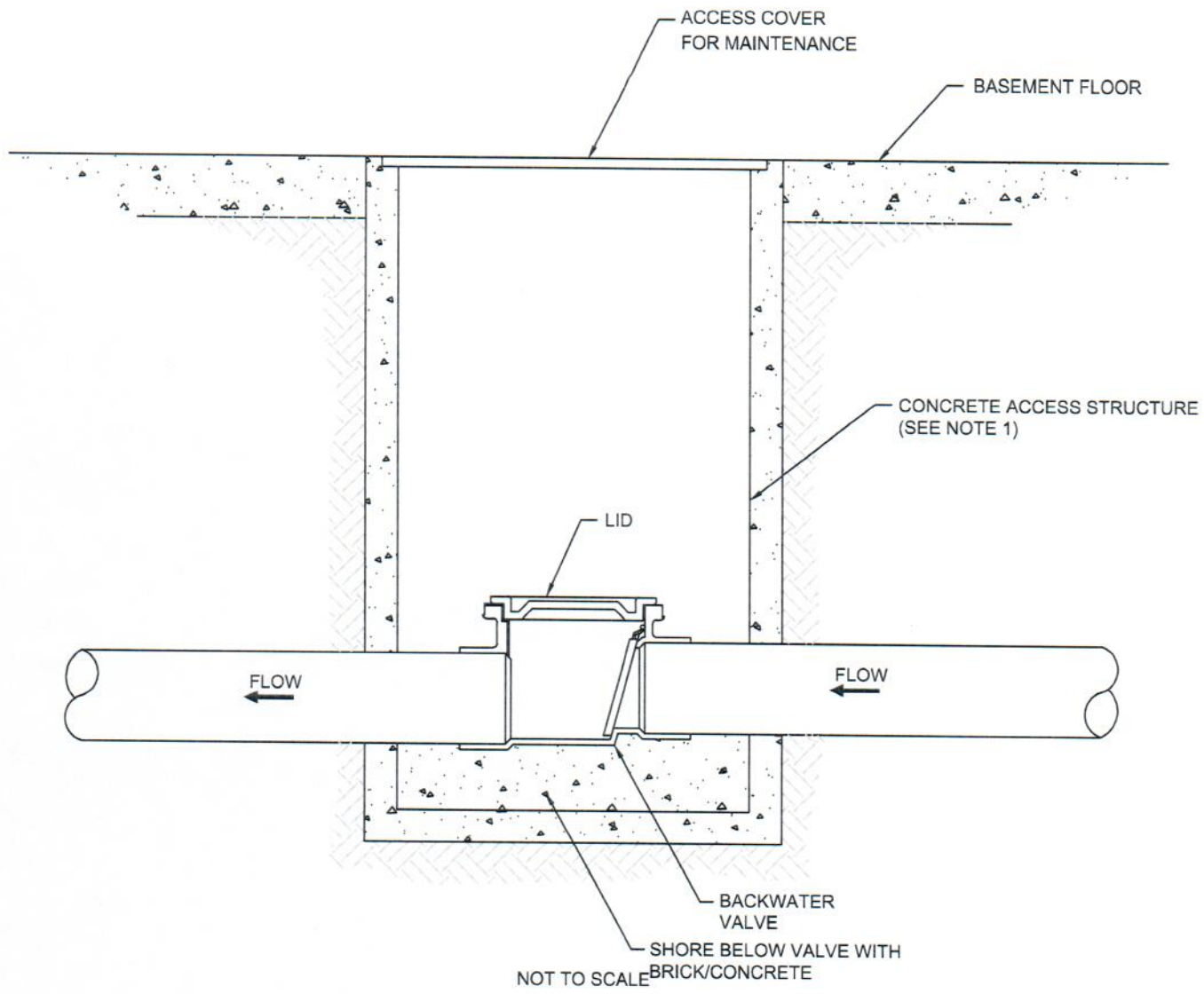

**NOTES:**

1. ACCESS STRUCTURE TO BE SIZED TO ALLOW FULL ACCESS TO BACKWATER VALVE FOR MAINTENANCE OR REPLACEMENT.



Town of **MEDWAY**  
DEPARTMENT OF PUBLIC SERVICES

**BACKWATER VALVE  
ASSEMBLY**

DATE: JULY 2016
REV: 0

DETAIL NO.  
**S-13**

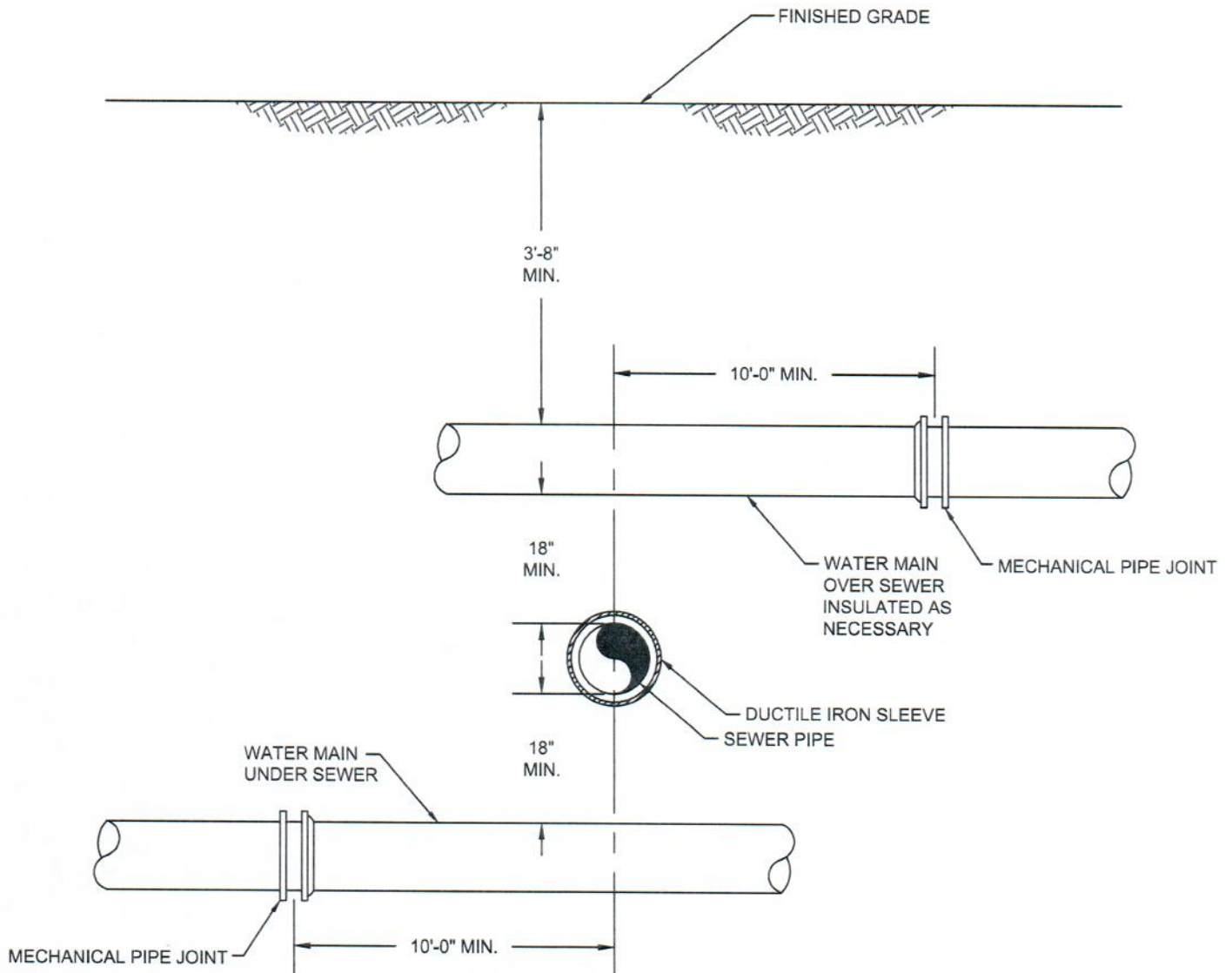

NOT TO SCALE

**NOTES:**

1. SEWERS SHALL BE KEPT REMOTE FROM WATER SUPPLY PIPING AND STRUCTURES. WHEREVER FEASIBLE, SEWERS SHOULD BE LAID AT A MINIMUM HORIZONTAL DISTANCE OF 10 FEET FROM WATER MAINS. IF LOCAL CONDITIONS PREVENT THIS, THE WATER MAIN SHOULD BE LAID IN A SEPARATE TRENCH, AND THE ELEVATIONS OF THE CROWN OF THE SEWER PLACED AT LEAST 18 INCHES BELOW THE INVERT OF THE WATER MAIN.
2. WHENEVER SEWERS MUST CROSS WATER MAINS, THE CROWN OF THE SEWER SHOULD BE PLACED A MINIMUM OF 18 INCHES BELOW THE INVERT OF THE WATER MAIN. IN ADDITION, THE WATER MAIN MUST BE CONSTRUCTED WITH ONE FULL LENGTH OF PIPE CENTERED ABOUT THE SEWER CROSSING. NEWLY INSTALLED WATER PIPE SHALL HAVE MECHANICAL JOINTS FOR A DISTANCE OF 10 FEET ON EACH SIDE OF THE SEWER CROSSING.
3. WHEN IT IS IMPOSSIBLE TO OBTAIN HORIZONTAL OR VERTICAL SEPARATION AS STIPULATED ABOVE, BOTH THE WATER AND THE SEWER SHOULD BE ENCASED IN CONTROL DENSITY FILL FOR A DISTANCE OF 10 FEET ON EITHER SIDE OF THE CROSSING.
4. SLEEVE SEWER PIPE USING DUCTILE IRON PIPE.



Town of **MEDWAY**  
DEPARTMENT OF PUBLIC SERVICES

**SEWER/WATER MAIN  
CROSSING**

DATE:  
JULY 2016  
REV:  
0

DETAIL NO.  
**S-14**

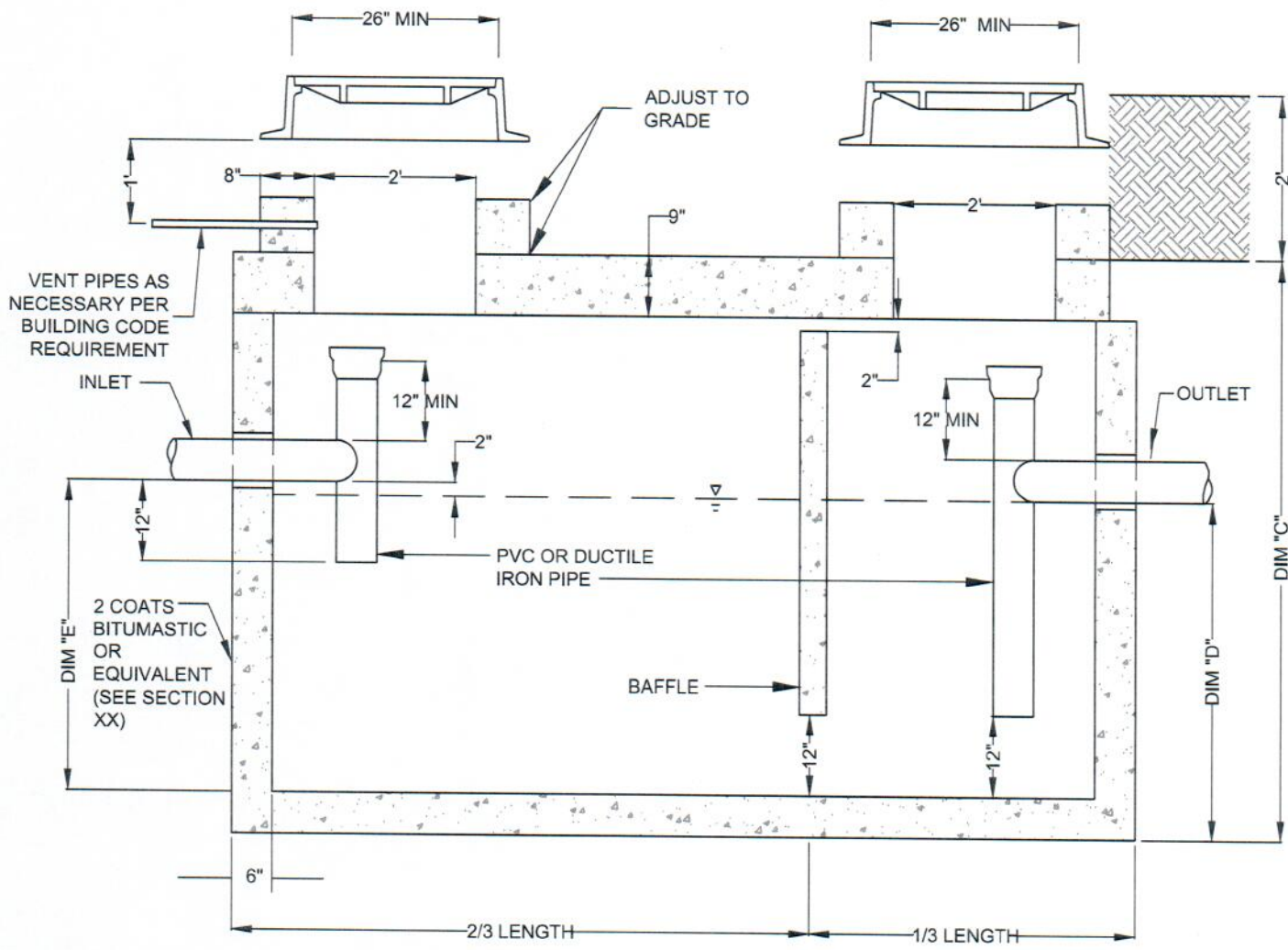
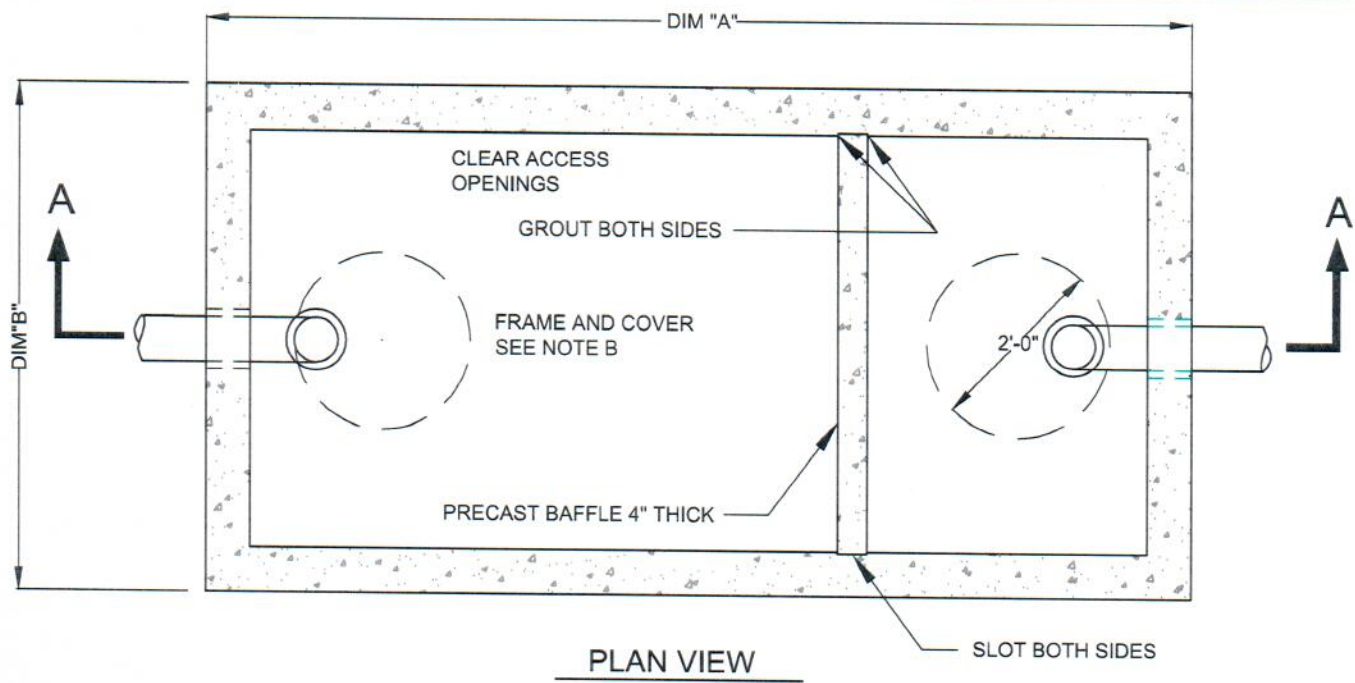

NOTES:  
 1. PER TOWN APPROVAL, INTERNAL AUTOMATED GREASE INTERCEPTOR MAY BE ALLOWED.

SECTION AA  
 NOT TO SCALE



Town of **MEDWAY**  
 DEPARTMENT OF PUBLIC SERVICES

EXTERNAL GREASE TRAP

DATE:  
 JULY 2016  
 REV:  
 0

DETAIL NO.  
**S-15**

## SIZING CHART

GALLON CAPACITY	DIM "A"	DIM "B"	DIM "C"	DIM "D"	DIM "E"
1000	9'-0"	5'-0"	7'-2"	4'-2"	3'-10"
1250	9'-0"	5'-0"	7'-2"	5'-2"	4'-10"
1500	11'-2"	5'-8"	7'-2"	4'-4"	4'-0"
1750	11'-2"	5'-8"	7'-2"	4'-11"	4'-7"
2000	12'-8"	6'-8"	8'-0"	4'-7"	3'-10"
2500	12'-8"	6'-8"	8'-0"	5'-6"	4'-9"
2750	12'-8"	6'-8"	8'-0"	6'-0"	5'-3"
3000	15'-7"	9'-7"	8'-6.5"	5'-0"	3'-9"
4000	15'-7"	9'-7"	8'-6.5"	6'-3"	5'-0"
5000	19'-11"	9'-11"	8'-11"	6'-2"	4'-9"
6000	19'-11"	9'-11"	10'-5"	7'-2"	5'-9"

**NOTES:**

1. CONCRETE : 28 DAY F'c= 4500 psi
2. REBAR : ASTM A615 GRADE 60.
3. MESH : ASTM A-185 GRADE 65
4. DESIGN : AC1318-83 BUILDING CODE ASTM C-857 MINIMUM STRUCTURAL DESIGN LOADING FOR UNDERGROUND PRECAST CONCRETE UTILITY STRUCTURES
5. LOADS : H-20 LOADING.
6. FILL WITH CLEAN WATER PRIOR TO START UP OF SYSTEM
7. LARGER SIZES MAY BE REQUIRED AS PER REVIEW OF FACILITY. TRAP SIZE WILL BE 1,000 GALLONS MINIMUM.
8. FRAME AND COVER SHALL BE PER TOWN OF MEDWAY SEWER CONSTRUCTION STANDARDS S-02.
9. SEE CONSTRUCTION STANDARDS FOR OTHER REQUIREMENTS.



Town of **MEDWAY**  
DEPARTMENT OF PUBLIC SERVICES

### TYPICAL GREASE TRAP SIZING AND NOTES

DATE:  
JULY 2016  
REV:  
0

DETAIL NO.  
**S-16**





**TOWN OF MEDWAY  
WATER & SEWER ADVISORY BOARD  
MEDWAY, MASSACHUSETTS**

**Members**

Leo O'Rourke, Chair  
Tracy Stewart, Member  
David Dwyer, Member  
Frank Ward, Member

October 21, 2025

**Water & Sewer Fees**

Water Entrance Fee – Residential		<b>\$2500.00</b>	Per Dwelling Unit
Water Entrance Fee – Commercial		<b>2,500.00 Per Inch of Service Tap Size</b>	\$2,500.00 Minimum
Water Entrance Fee – Fire Service without meter		<b>\$2,000 per inch of tap size</b>	
Sewer Entrance Fee- New System		<b>\$4,000.00</b>	Per Dwelling Unit
Meter/MXU Installation 5/8"		<b>At Cost + 10%</b>	Currently \$370 for the Meter and MXU setup (includes cellar valve)
Meter/MXU Installation 1"		<b>At Cost + 10%</b>	Currently \$457 for the Meter and MXU setup (includes cellar valve)
Meter/MXU Installation Greater than 1"		<b>At Cost + 10%</b>	Currently at cost for the Meter and MXU setup (includes cellar valve)
Backflow Test		<b>\$50.00</b>	
Second Meter		<b>\$500.00</b>	Currently \$280 for the Meter & MXU
Meter Replacement (Damaged/Frozen)	Plus Service call	<b>At Cost + 10%</b>	Currently \$208 for a 5/8' meter Plus service call
MXU Replacement (Damaged)	Plus Service Call	<b>At Cost + 10%</b>	Currently \$151 for MXU Plus service call
Meter Test	5/8"-1" Meter	<b>\$300.00</b>	Larger Meters @ Cost
Fire Flow Test	During Normal Work Hours	<b>\$100.00</b>	
Fire Flow Test	After Hours	<b>\$250.00</b>	
Water Turn On/Off Fee	During Normal Work Hours	<b>\$75.00</b>	
Water Turn On/Off Fee	After Hours	<b>\$225.00</b>	
Hydrant Meter	Non-Refundable Setup Fee	<b>\$75.00</b>	
	Monthly rental Fee (30 days)	<b>\$50.00</b>	
	Water Charges	<b>Usage</b>	See current Rate Schedule
	Refundable Deposit (1")	<b>\$950.00</b>	\$293 meter, \$644 backflow
	Refundable Deposit (2")	<b>\$2335.00</b>	\$1030 meter, \$1240 backflow
Water Ban Violation	First Offense	<b>Warning</b>	
	Second Offense	<b>\$100.00</b>	
	Third Offense/ Subsequent Offenses	<b>\$300.00</b>	Fee Per Day, Can lead to service termination and \$65 restoration fee

